



# 05177300 - LT-S VDI50 ER40F OFS75 2:1 RF H110

Type	LT-S OFS Tool holder straight offset
Mounting	VDI 50
Tool output	Collet nut ER 40 F - internal nut
Coolant	Internal coolant
Offset [mm]	75
Direction of rotation	r1  r2 
Max speed [rpm]	in 6000 / out 3000
Max torque [Nm]	in 100 / out 200
Ratio	2:1
H [mm]	110
Max pressure [bar]	20
Accessories	N.A.
Notes	N.A.
Mounting tips	N.A.



**ATTENTION: CHECK THE ORIENTATION OF THE VDI TEETH**

Always check live tool dimensions on the turret

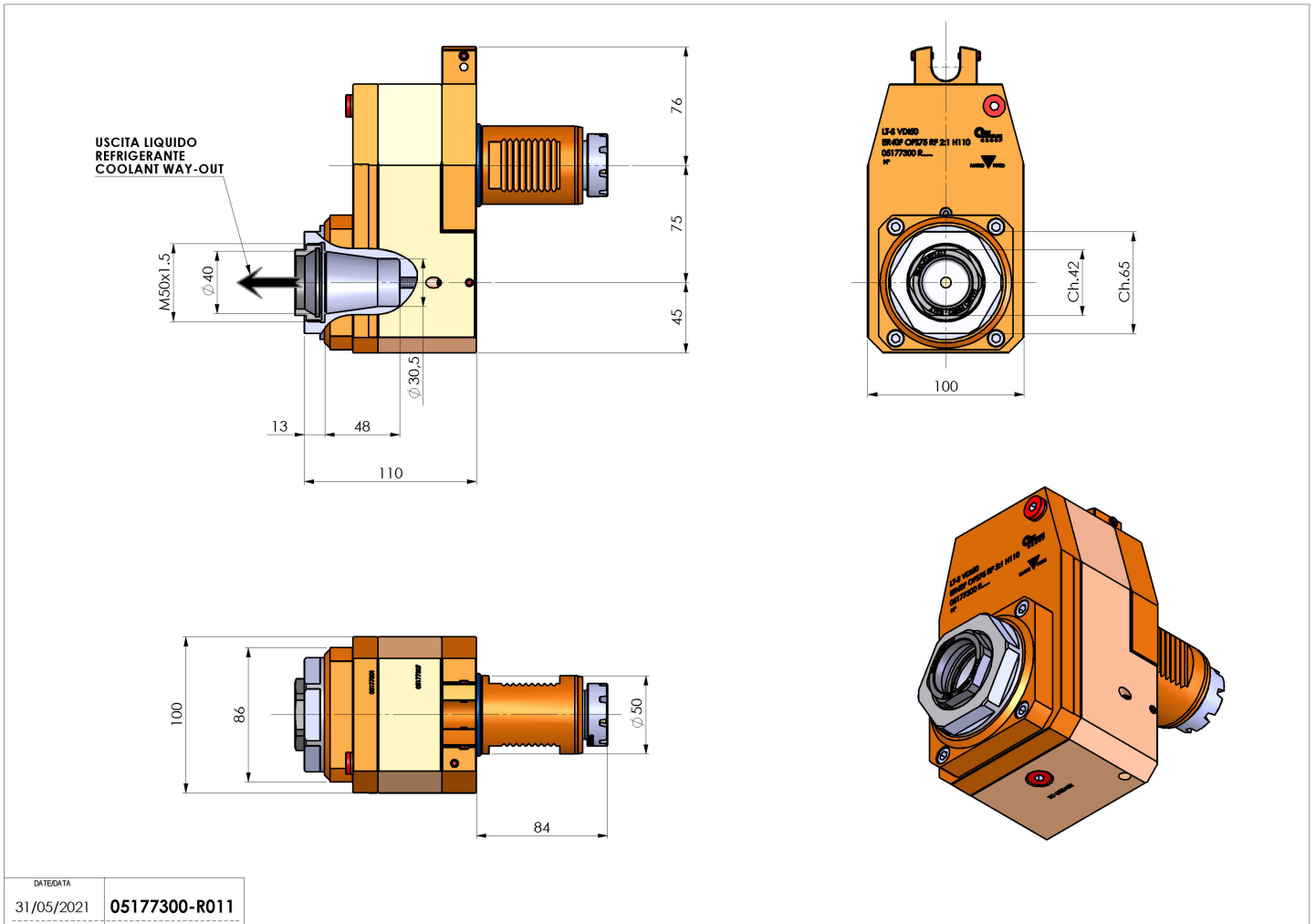

DATE/GATE	31/05/2021	05177300-R011
-----------	------------	---------------

Subject to technical changes