

05162400 - LT-A D44 ER25F L-R HS H60

Type	LT-A Tool holder angle 90°
Mounting	CYLINDRICAL SHANK 44
Tool output	Collet nut ER 25 F - internal nut
Coolant	External coolant
Direction of rotation	r1 r2
Max speed [rpm]	10000
Max torque [Nm]	30
Ratio	1:1
H [mm]	60
H1 [mm]	32,5
Accessories	N.A.
Notes	N.A.
Mounting tips	N.A.

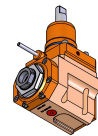

Always check live tool dimensions on the turret

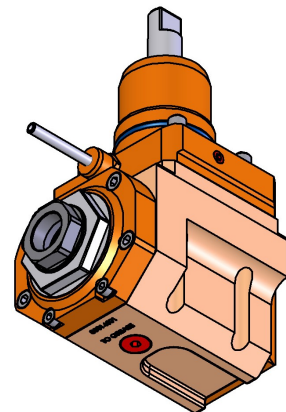
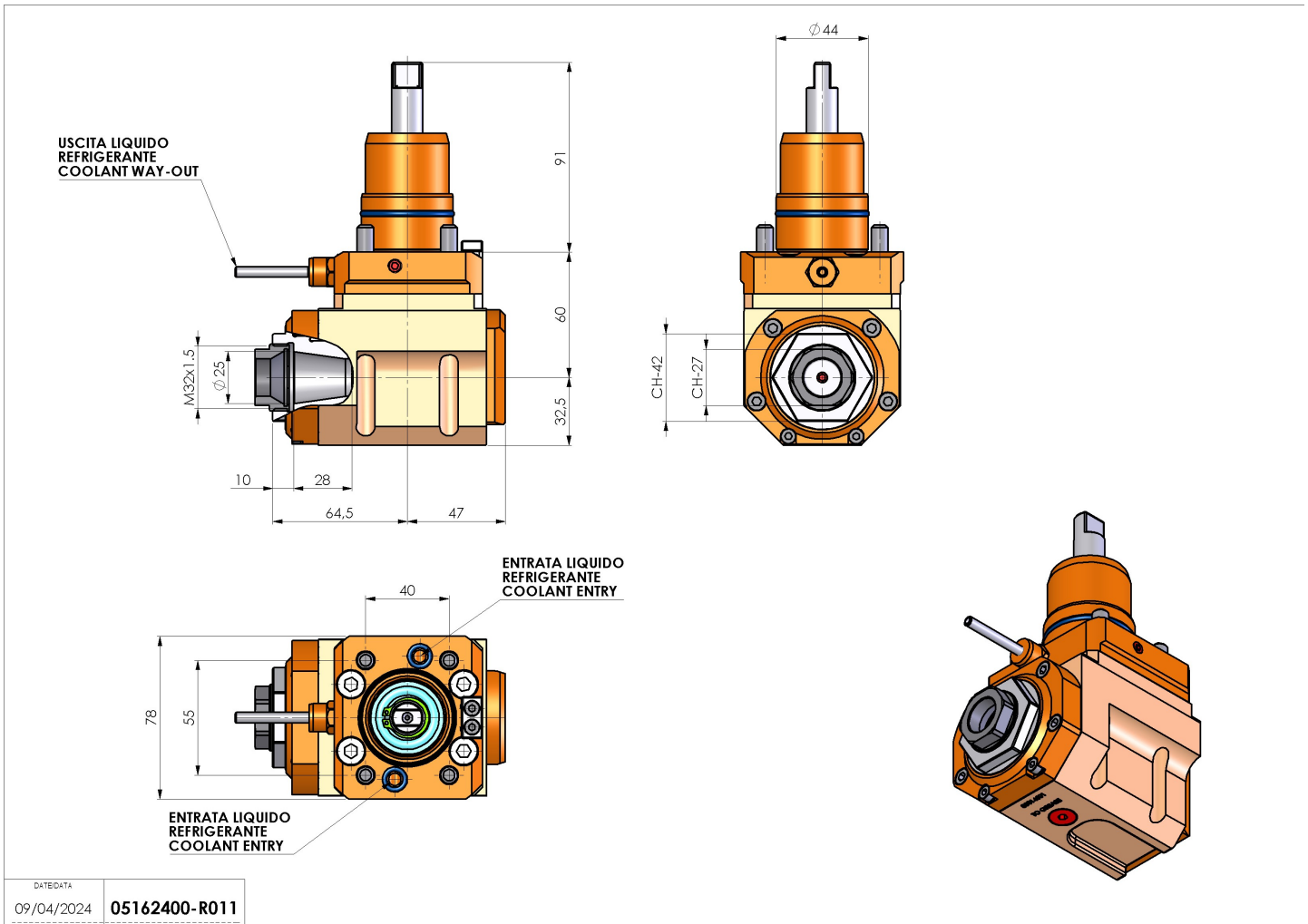

Subject to technical changes