



05161200 - LT-S D35ER20FOF38.25RF2:1H95MU

Type	LT-S OFS Tool holder straight offset
Mounting	CYLINDRICAL SHANK 35
Tool output	Collet nut ER 20 F - internal nut
Coolant	Internal coolant
Offset [mm]	38,25
Direction of rotation	r1  r2 
Max speed [rpm]	in 6000 / out 3000
Max torque [Nm]	in 10 / out 20
Ratio	2:1
H [mm]	95
Max pressure [bar]	20
Accessories	N.A.
Notes	N.A.
Mounting tips	N.A.



Always check live tool dimensions on the turret

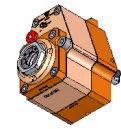
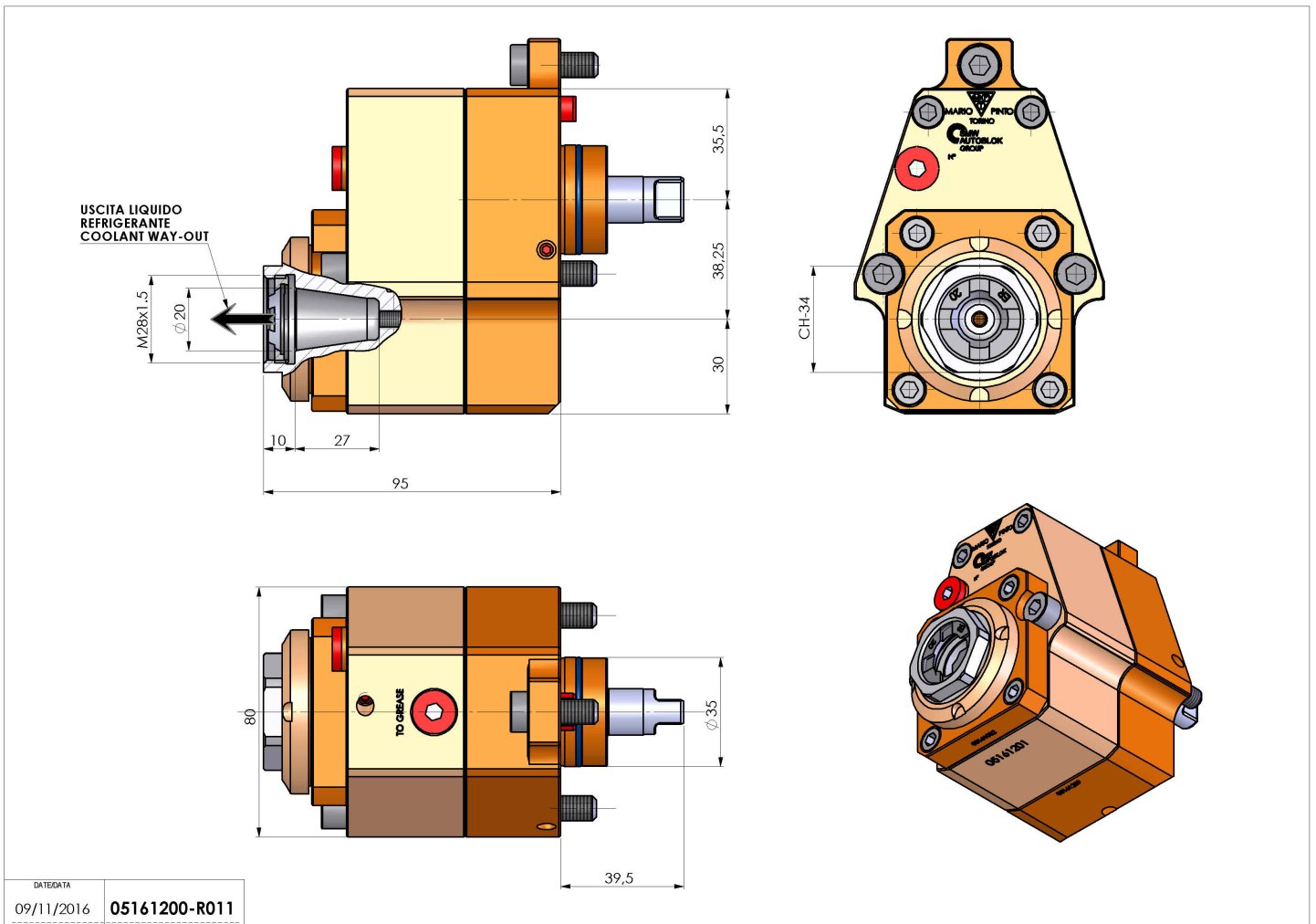

DATE/DATA	09/11/2016
	05161200-R011

Subject to technical changes