

05160000 - LT-S D35 ER20F H63 MU

Type	LT-S Tool holder straight
Mounting	CYLINDRICAL SHANK 35
Tool output	Collet nut ER 20 F - internal nut
Coolant	External coolant
Direction of rotation	r1 r2
Max speed [rpm]	6000
Max torque [Nm]	25
Ratio	1:1
H [mm]	63
Accessories	
Notes	N.A.
Mounting tips	N.A.

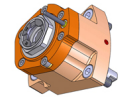

Always check live tool dimensions on the turret

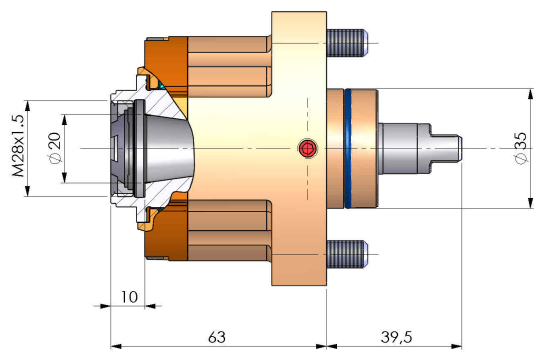

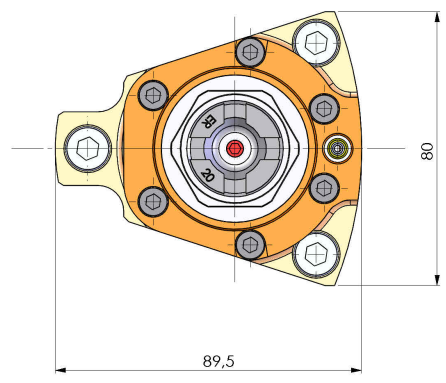

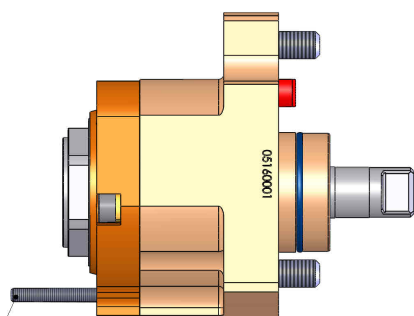

USCITA LIQUIDO
REFRIGERANTE
COOLANT WAY-OUT

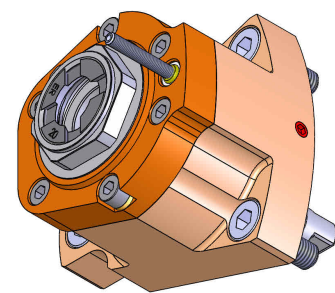

DATE/DATE
10/09/2015
05160000-R011

Subject to technical changes