

05158400 - LT-A2 D55 HSK40 I-88 LR H125MU

Type	LT-A2 H Tool holder angle 90° double horizontal
Mounting	CYLINDRICAL SHANK 55
Tool output	Quick Change HSK40
Coolant	External coolant
Direction of rotation	r1 ↻ r2 ↻
Max speed [rpm]	4000
Max torque [Nm]	63
Ratio	1:1
H [mm]	125
H1 [mm]	40
Accessories	N.A.
Notes	N.A.
Mounting tips	N.A.

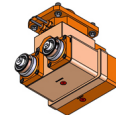

Always check live tool dimensions on the turret

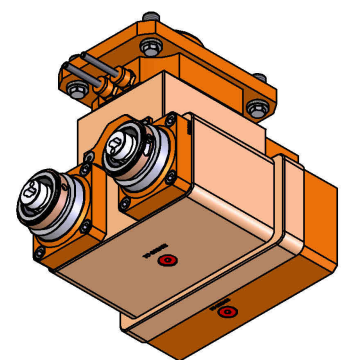
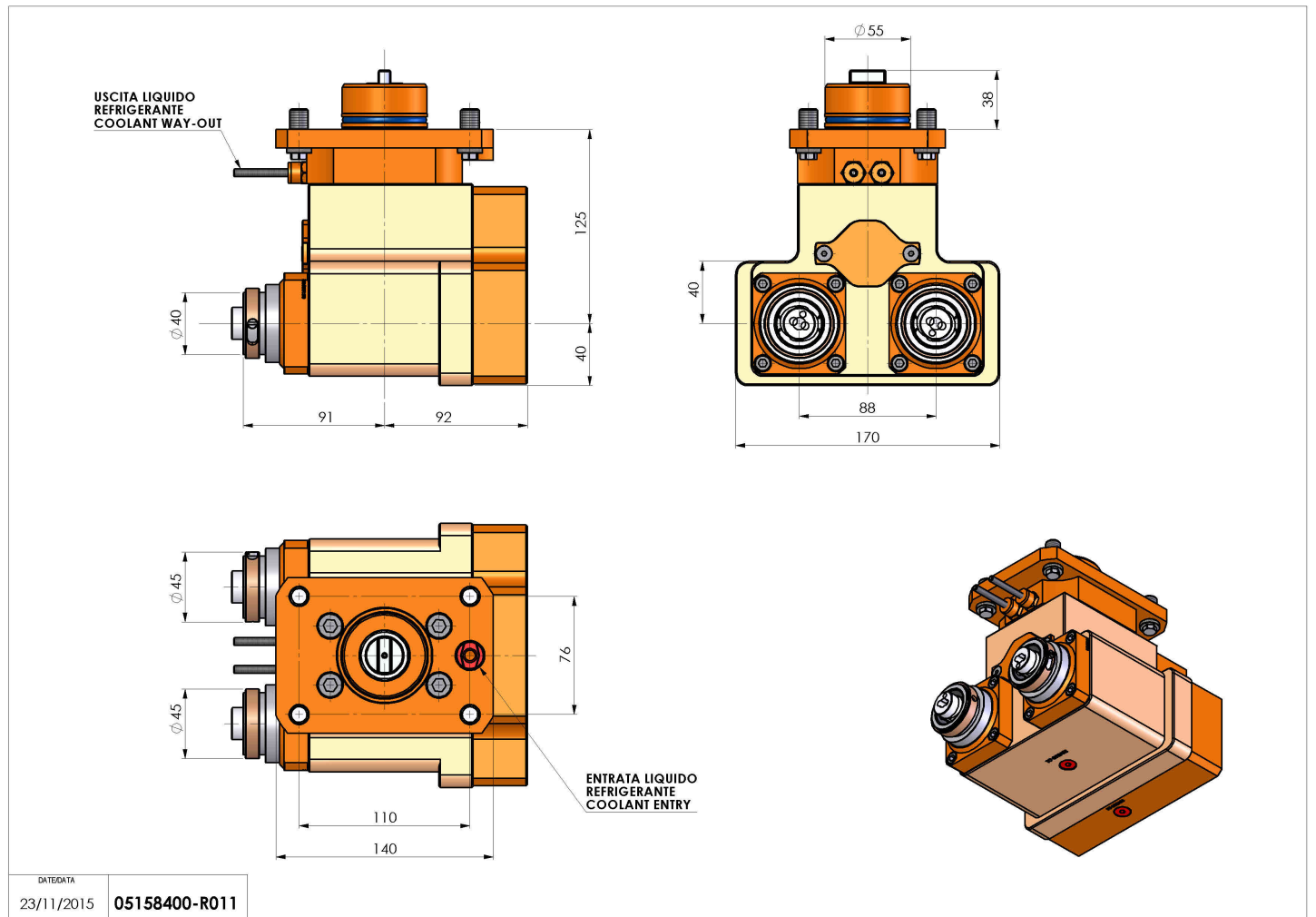

DATE/DATA	05158400-R011
23/11/2015	

Subject to technical changes