

05158100 - LT-S D55 ER20F OFS78 RF 1:3 MU

| | |
|------------------------------|---|
| Type | LT-S OFS Tool holder straight offset |
| Mounting | CYLINDRICAL SHANK 55 |
| Tool output | Collet nut ER 20 F - internal nut |
| Coolant | Internal coolant |
| Offset [mm] | 78 |
| Direction of rotation | r1 ↻ r2 ↻ |
| Max speed [rpm] | in 5000 / out 15000 |
| Max torque [Nm] | in 50 / out 14 |
| Ratio | 1:3 |
| H [mm] | 121 |
| Max pressure [bar] | 20 |
| Accessories | N.A. |
| Notes | N.A. |
| Mounting tips | N.A. |

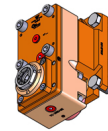

Always check live tool dimensions on the turret

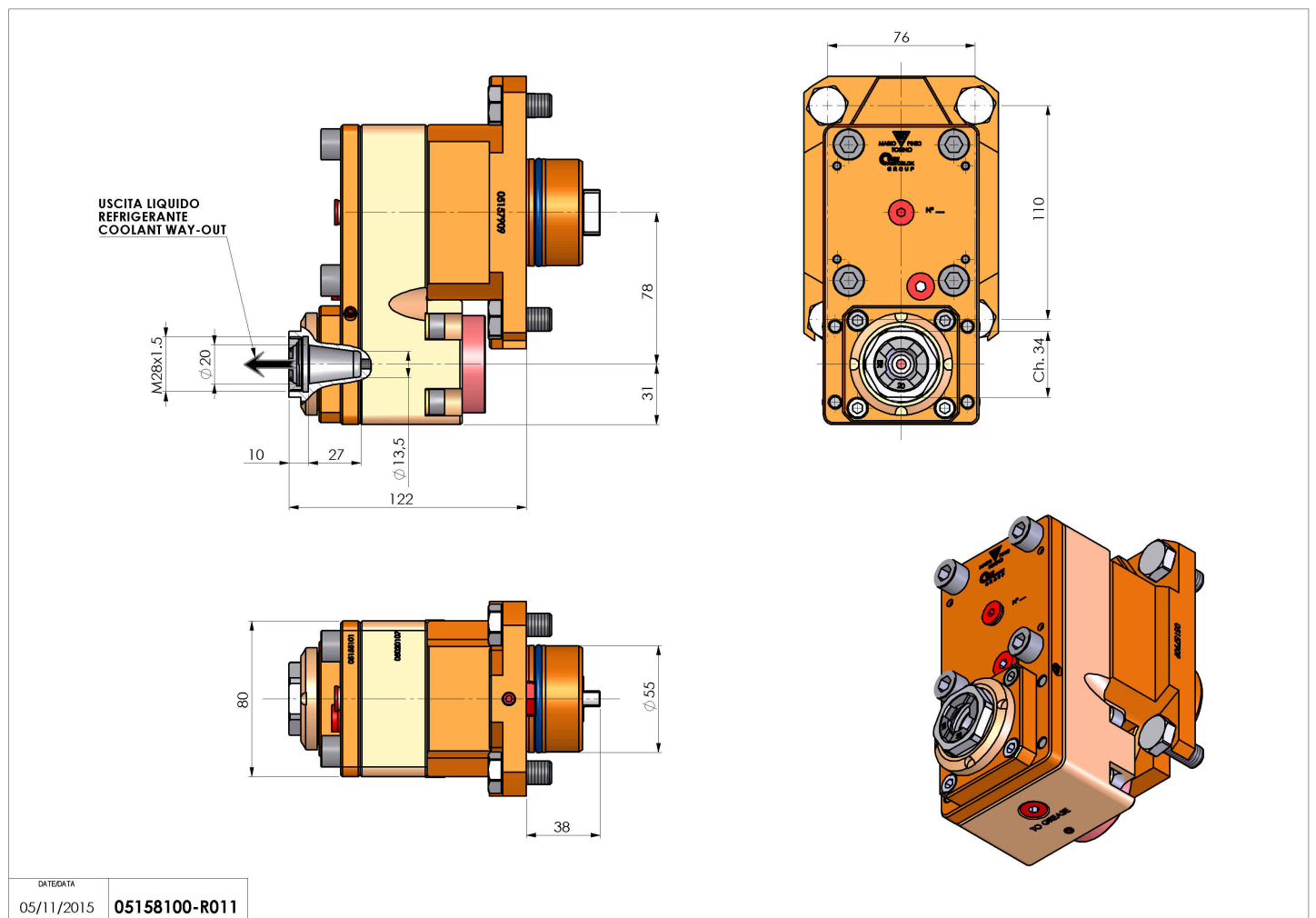

Subject to technical changes