

05155900 - LT-S D40DIN138-22OFS72LR H93MU

Type	LT-S OFS Tool holder straight offset
Mounting	CYLINDRICAL SHANK 40
Tool output	Shell-Mill DIN138 22
Coolant	External coolant
Offset [mm]	72
Direction of rotation	r1 ↻ r2 ↻
Max speed [rpm]	6000
Max torque [Nm]	50
Ratio	1:1
H [mm]	93
Accessories	N.A.
Notes	N.A.
Mounting tips	N.A.

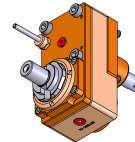

Always check live tool dimensions on the turret

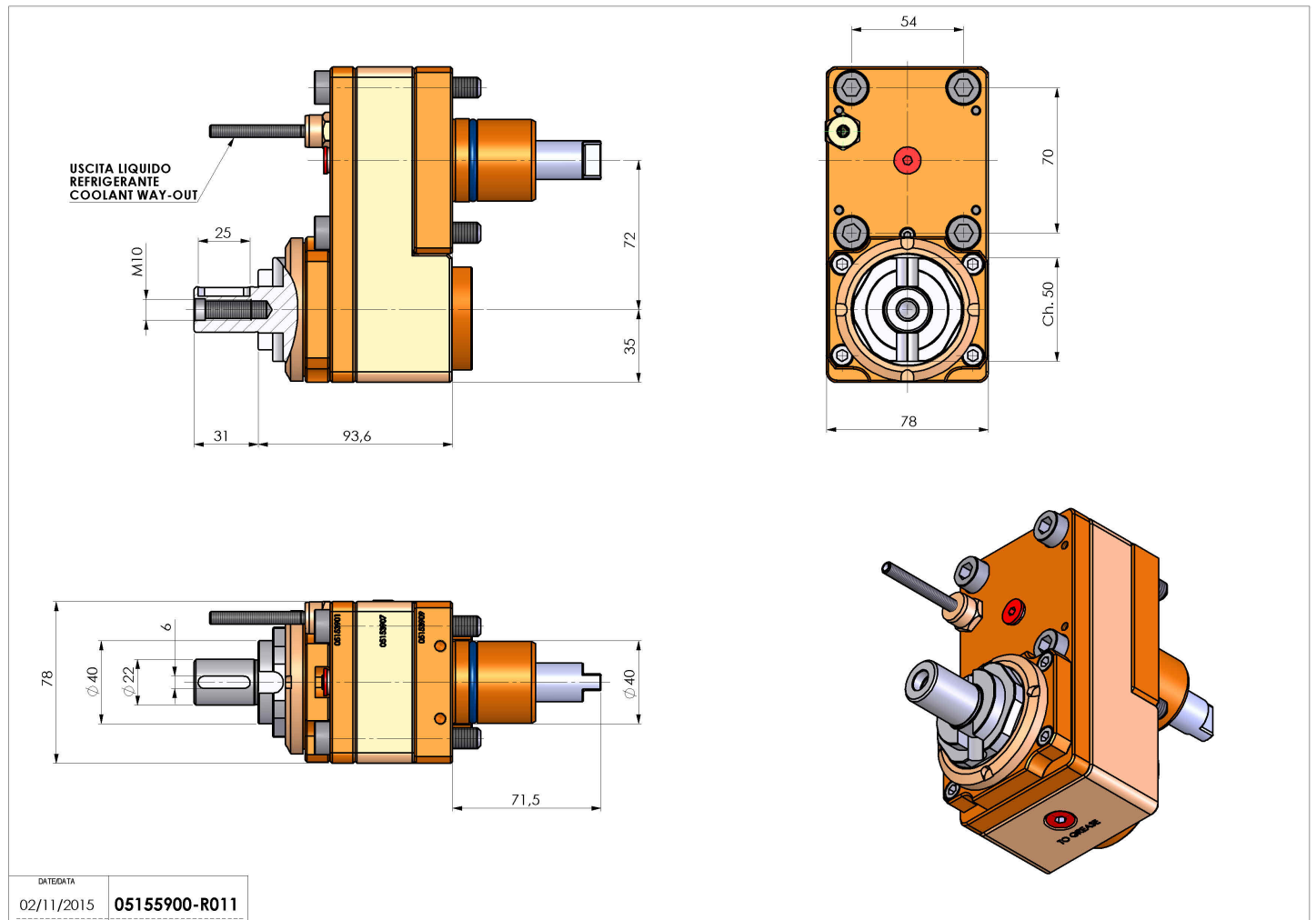

DATE/DATE	02/11/2015	05155900-R011
-----------	------------	---------------

Subject to technical changes