

05153000 - LT-S2 D40 ER20F-20F H122 1:2MU

Type	LT-S2 Tool holder double straight
Mounting	CYLINDRICAL SHANK 40
Tool output	Collet nut ER 20 F - internal nut
Coolant	External coolant
Direction of rotation	
Max speed [rpm]	in 6000 / out 12000
Max torque [Nm]	in 38 / out 16
Ratio	1:2
H [mm]	122
Accessories	N.A.
Notes	N.A.
Mounting tips	N.A.

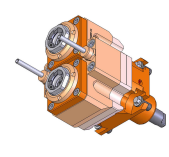

Always check live tool dimensions on the turret

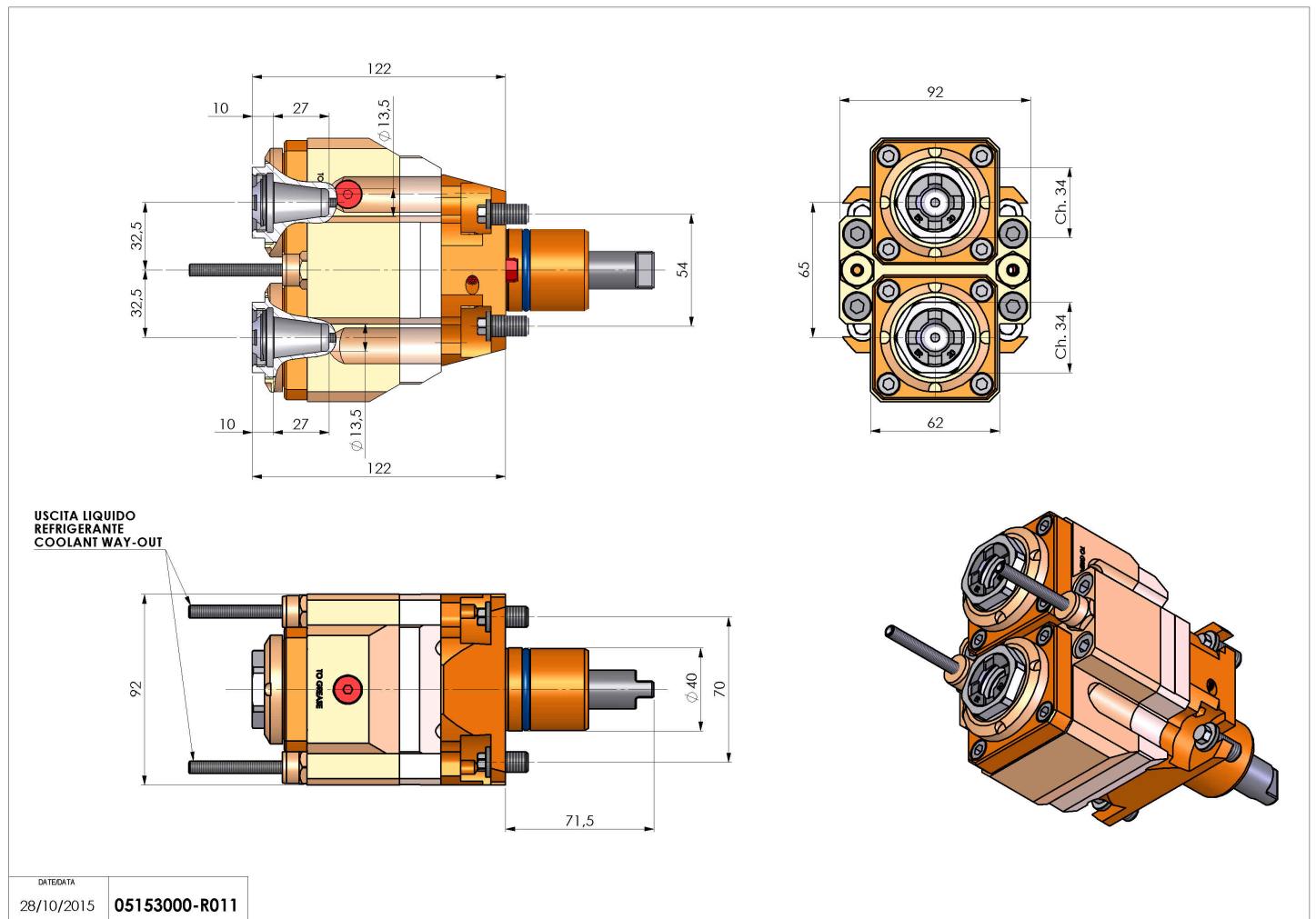

DATE/DATA	
28/10/2015	05153000-R011

Subject to technical changes