

## 05152000 - LT-SVDI40ER20FOF781:3KR HRFH90

Type	LT-S OFS Tool holder straight offset
Mounting	VDI 40
Tool output	Collet nut ER 20 F - internal nut
Coolant	HRF Internal coolant
Offset [mm]	78
Direction of rotation	r1 ↻ r2 ↻
Max speed [rpm]	in 5000 / out 15000
Max torque [Nm]	in 50 / out 14
Ratio	1:3
H [mm]	89,5
Max pressure [bar]	80
Accessories	N.A.
Notes	N.A.
Mounting tips	N.A.

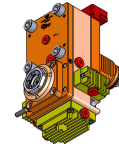

**ATTENTION: CHECK THE ORIENTATION OF THE VDI TEETH**

Always check live tool dimensions on the turret

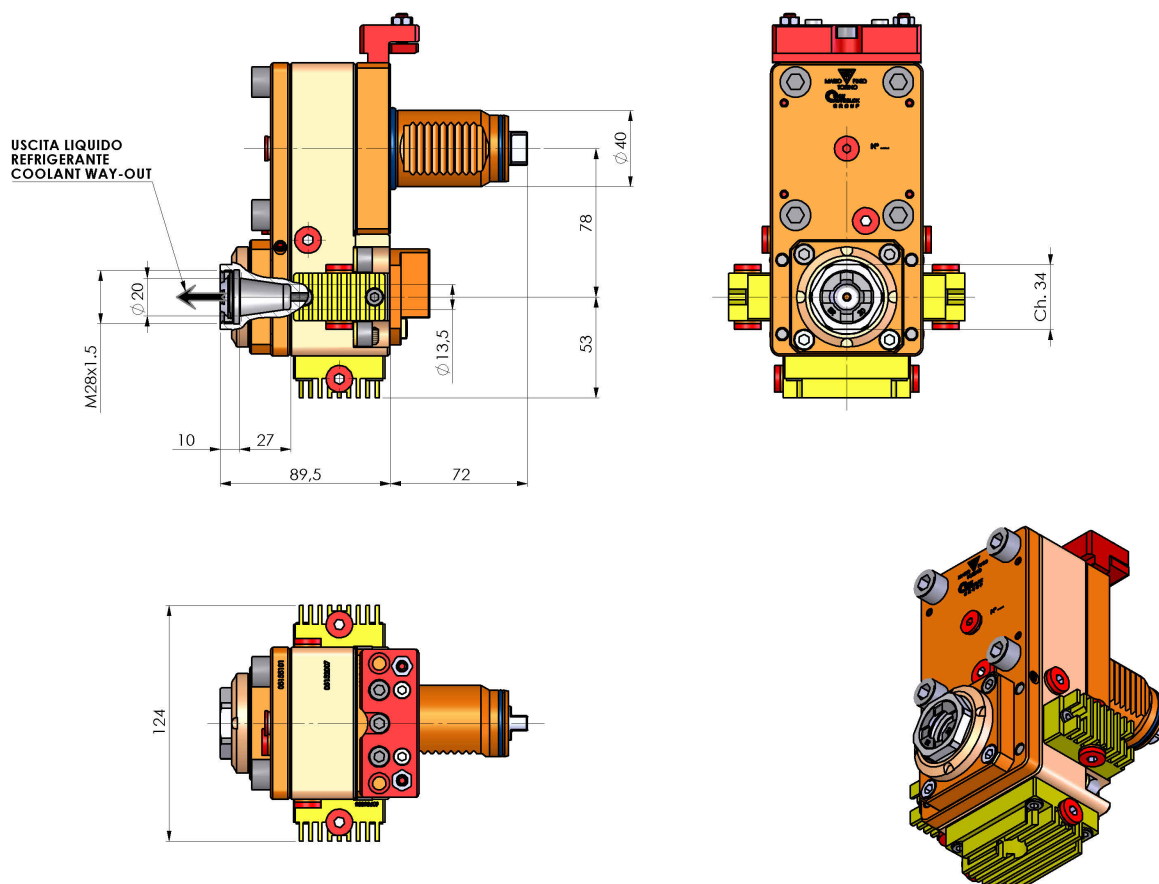

DATE/DATE	27/10/2015	05152000-R011
-----------	------------	---------------

Subject to technical changes