

05140100 - LT-A D88 ER32 L H120 OW

Type	LT-A Tool holder angle 90°
Mounting	CYLINDRICAL SHANK 88
Tool output	Collet nut ER 32
Coolant	External coolant
Direction of rotation	r1 ↻ r2 ↻
Max speed [rpm]	6000
Max torque [Nm]	63
Ratio	1:1
H [mm]	120
H1 [mm]	37
Accessories	N.A.
Notes	N.A.
Mounting tips	Main spindle only

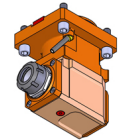

Always check live tool dimensions on the turret

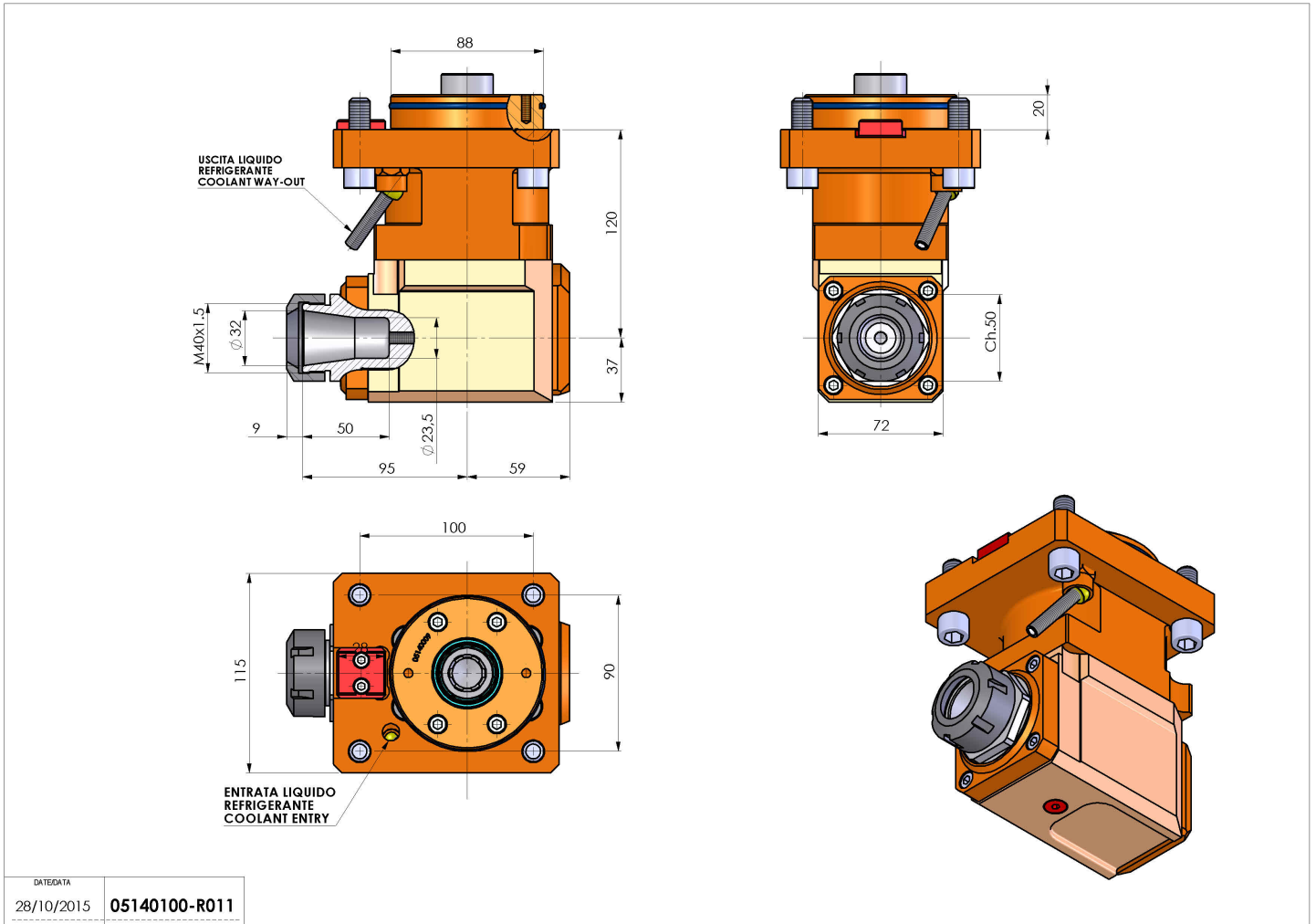

Subject to technical changes