

## 05129100 - LT-S BMT75ER40F OFS95 2:1H108

<b>Type</b>	LT-S OFS Tool holder straight offset
<b>Mounting</b>	BMT 75
<b>Tool output</b>	Collet nut ER 40 F - internal nut
<b>Coolant</b>	External coolant
<b>Offset [mm]</b>	95
<b>Direction of rotation</b>	r1  r2
<b>Max speed [rpm]</b>	in 4000 / out 2000
<b>Max torque [Nm]</b>	in 120 / out 240
<b>Ratio</b>	2:1
<b>H [mm]</b>	108
<b>Accessories</b>	N.A.
<b>Notes</b>	N.A.
<b>Mounting tips</b>	N.A.

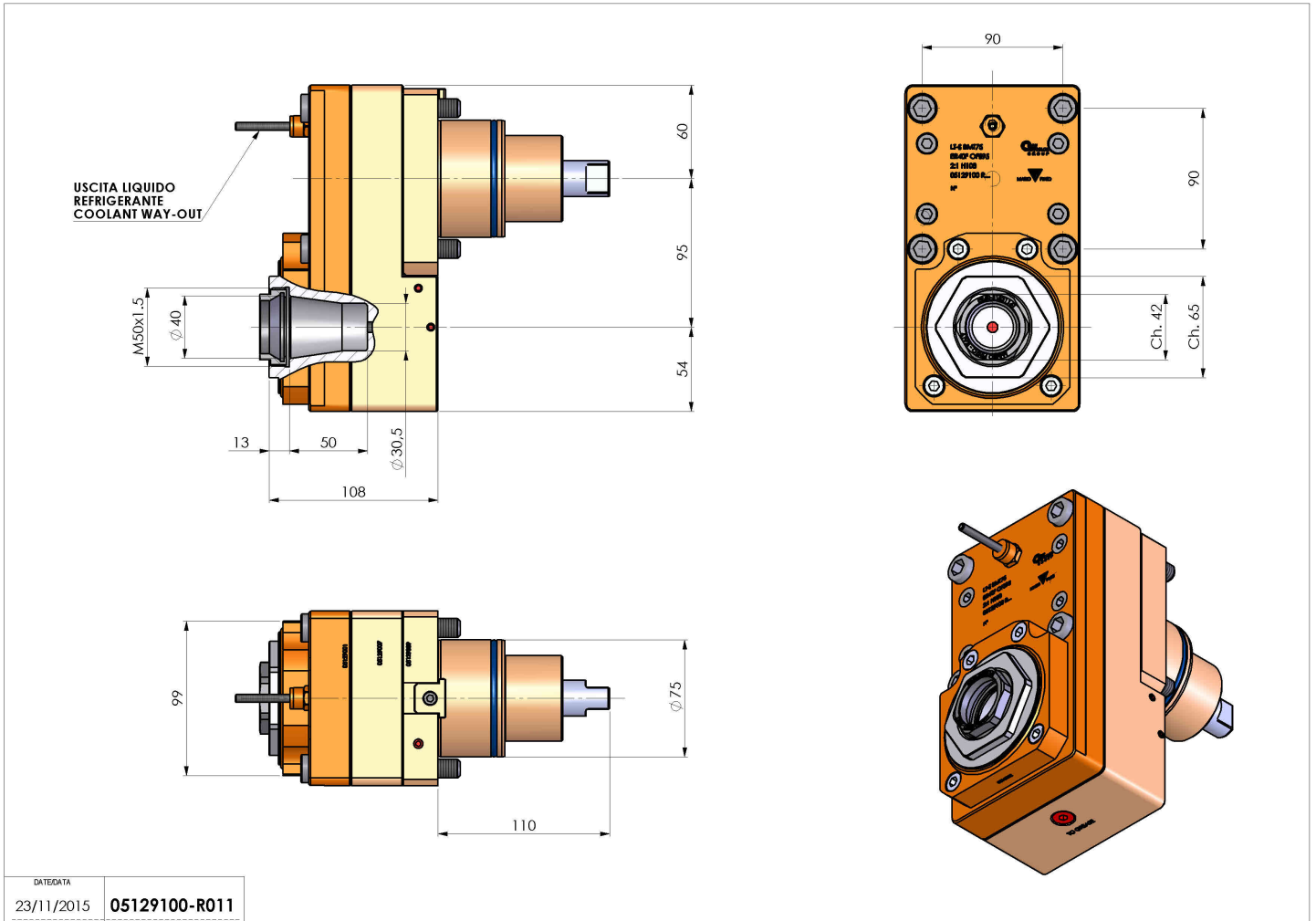

Always check live tool dimensions on the turret



Subject to technical changes