

05123900 - LT-A BMT75 ISOBT40 L-R H90 DW

Type	LT-A Tool holder angle 90°
Mounting	BMT 75
Tool output	Quick Change ISO-BT40
Coolant	External coolant
Direction of rotation	r1 ↻ r2 ↻
Max speed [rpm]	4000
Max torque [Nm]	180
Ratio	1:1
H [mm]	90
H1 [mm]	52
Accessories	N.A.
Notes	N.A.
Mounting tips	N.A.

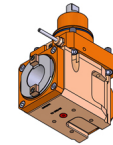

Always check live tool dimensions on the turret

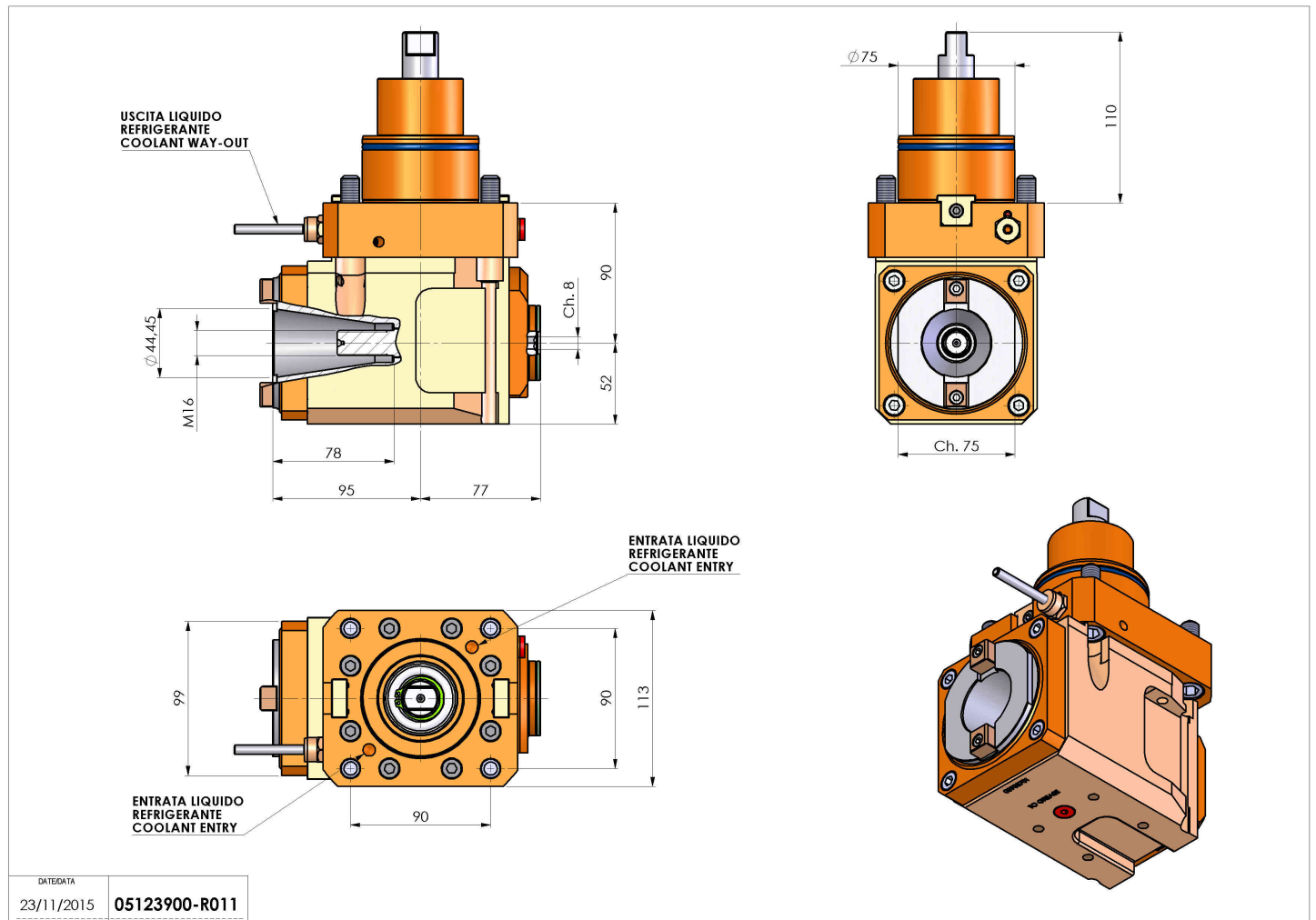

DATE/DATE	05123900-R011
23/11/2015	

Subject to technical changes