

# 05123700 - LT-S BMT75 ISOBT40 OFS110RFH80

Type	LT-S OFS Tool holder straight offset
Mounting	BMT 75
Tool output	Quick Change ISO-BT40
Coolant	Internal coolant
Offset [mm]	110
Direction of rotation	r1 ↻ r2 ↻
Max speed [rpm]	4000
Max torque [Nm]	180
Ratio	1:1
H [mm]	80
Max pressure [bar]	20
Accessories	N.A.
Notes	N.A.
Mounting tips	N.A.

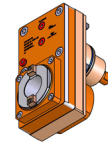

Always check live tool dimensions on the turret

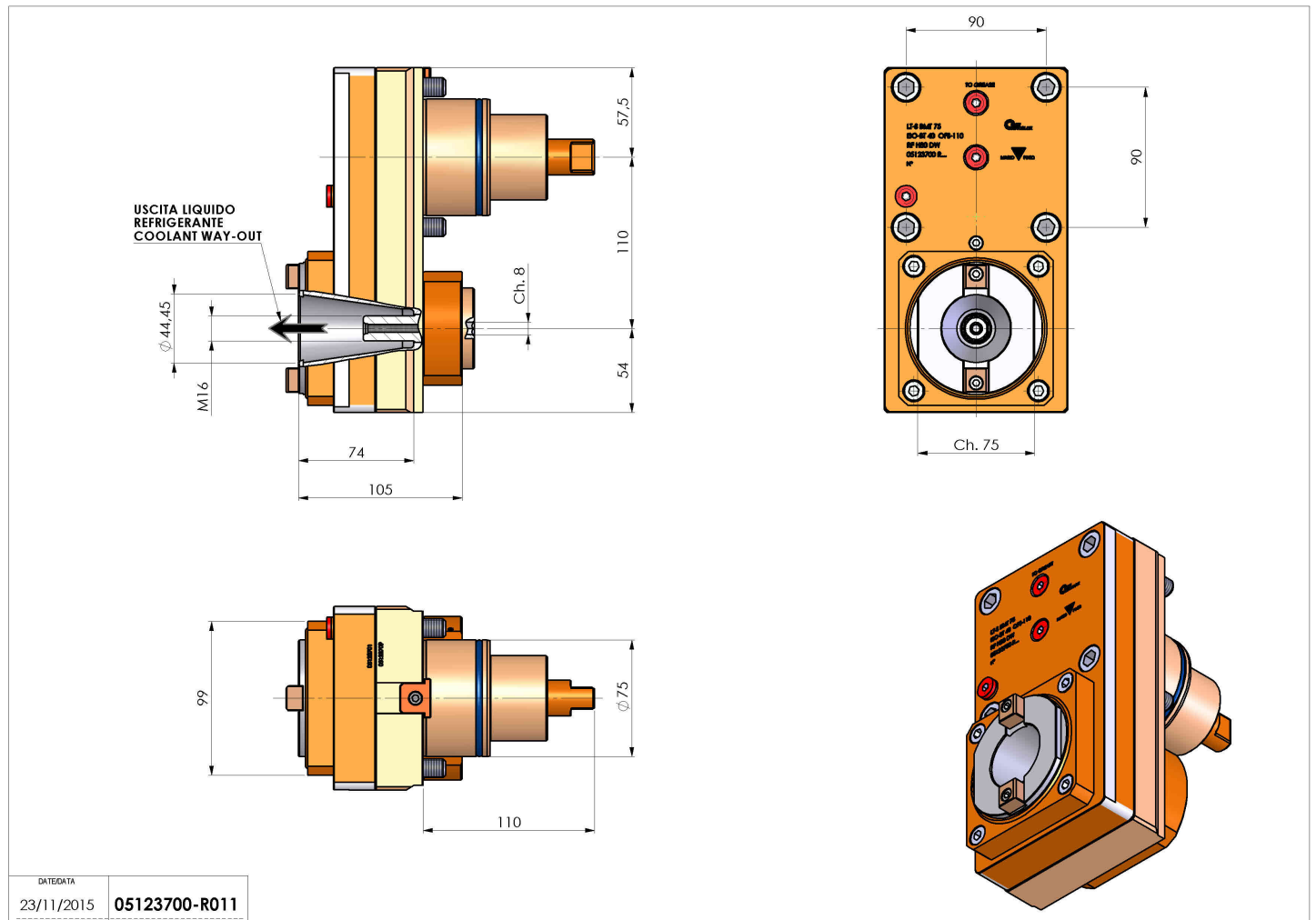

DATE/DATE	05123700-R011
23/11/2015	

Subject to technical changes