



05122100 - LT-A BMT65 ER32F OFS H86 DW

Type	LT-A OFS Tool holder offset angle 90°
Mounting	BMT 65
Tool output	Collet nut ER 32 F - internal nut
Coolant	External coolant
Direction of rotation	r1  r2 
Max speed [rpm]	6000
Max torque [Nm]	50
Ratio	1:1
H [mm]	86
H1 [mm]	38
Accessories	N.A.
Notes	N.A.
Mounting tips	Secondary spindle only



Always check live tool dimensions on the turret

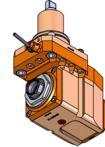
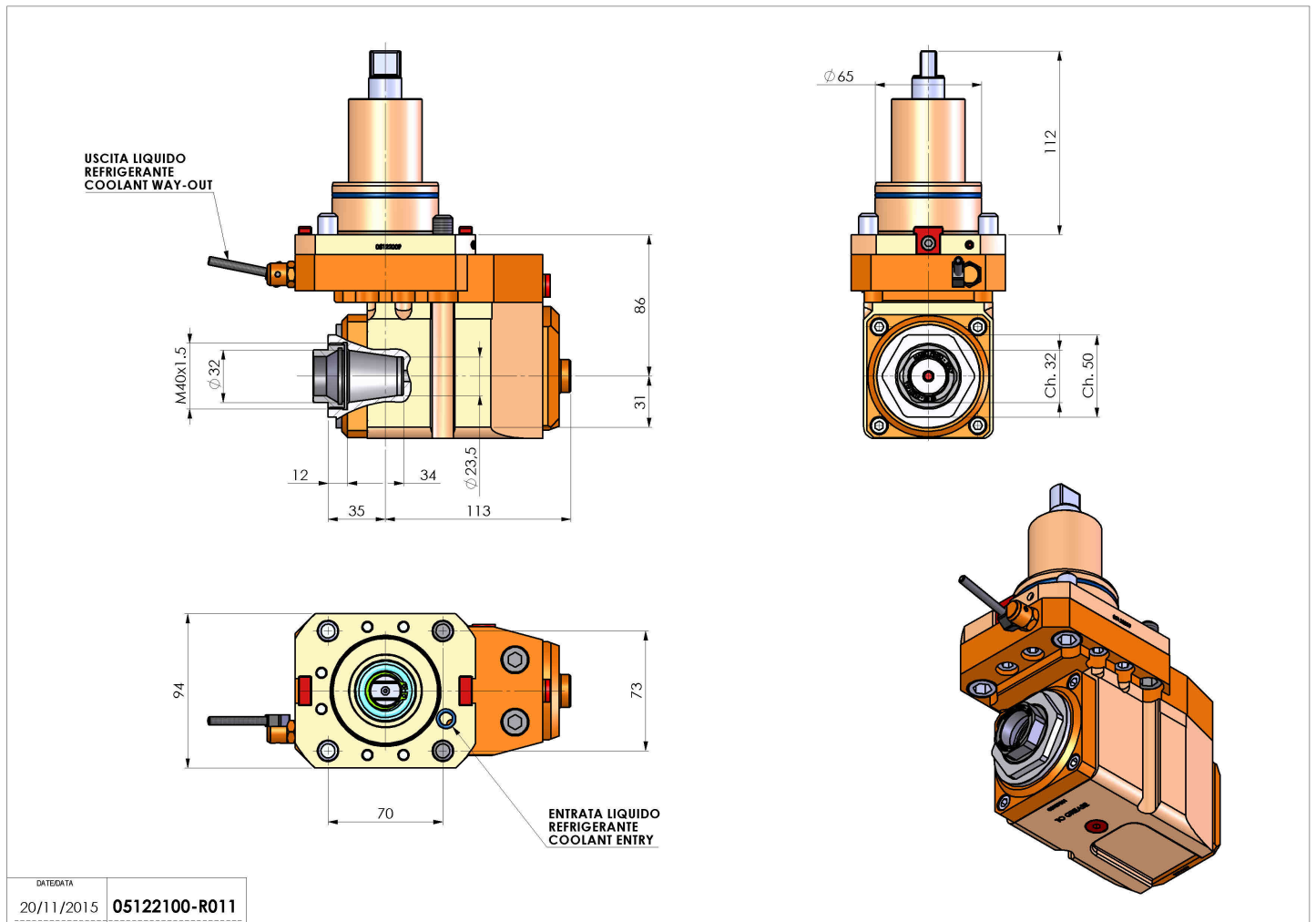

DATE/DATE	05122100-R011
20/11/2015	

Subject to technical changes