

# 05090400 - LT-A D25 ER25-F L-R RF H60 RO

<b>Type</b>	LT-A Tool holder angle 90°
<b>Mounting</b>	CYLINDRICAL SHANK 25
<b>Tool output</b>	Collet nut ER 25 F - internal nut
<b>Coolant</b>	Internal coolant
<b>Direction of rotation</b>	r1 ↻ r2 ↻
<b>Max speed [rpm]</b>	6000
<b>Max torque [Nm]</b>	25
<b>Ratio</b>	1:1
<b>H [mm]</b>	60
<b>H1 [mm]</b>	32,5
<b>Max pressure [bar]</b>	20
<b>Accessories</b>	N.A.
<b>Notes</b>	N.A.
<b>Mounting tips</b>	N.A.

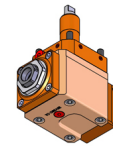

Always check live tool dimensions on the turret

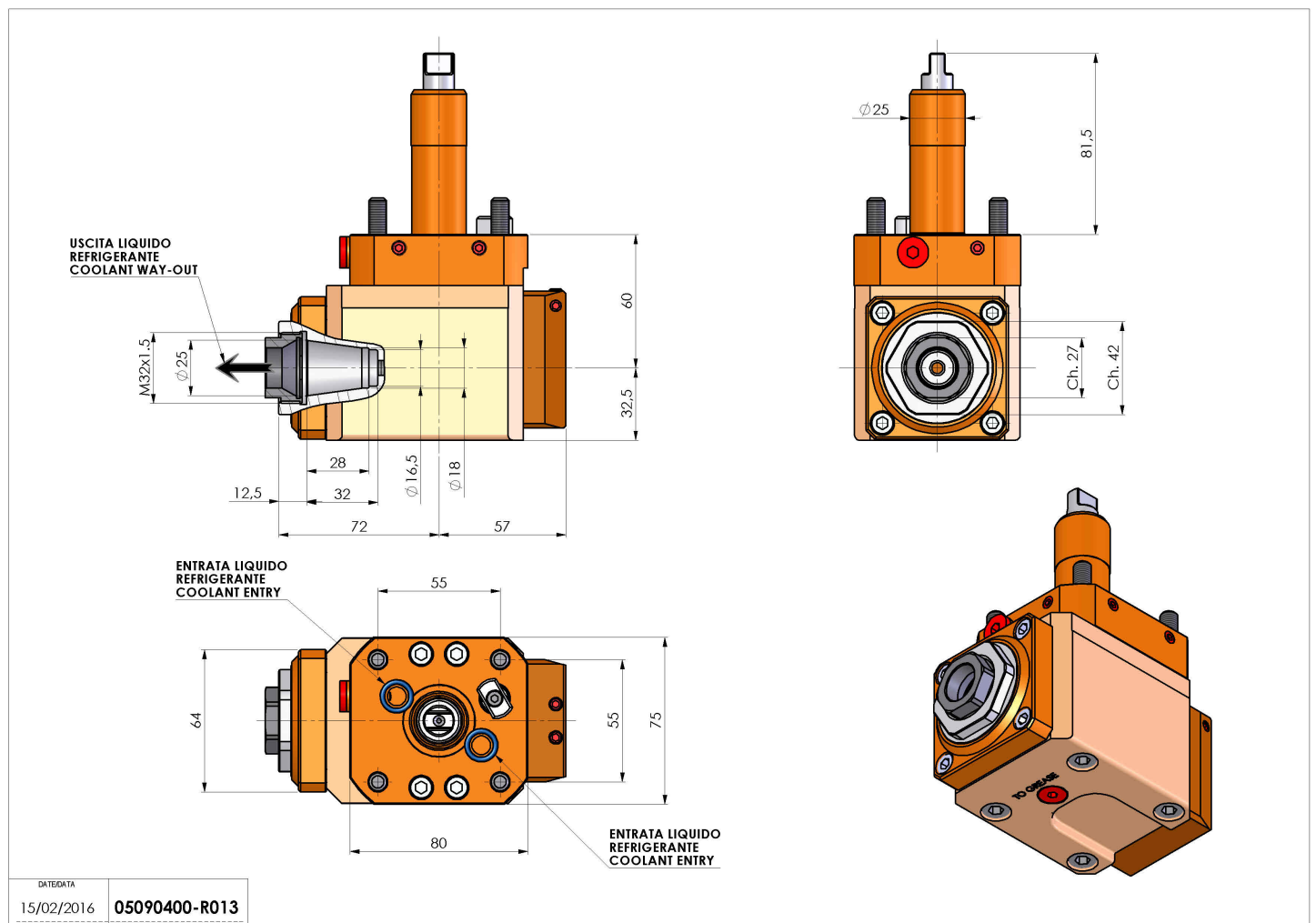

**Subject to technical changes**