

## 05077600 - LT-HOB-SAW D55 2,5:1 H90

|                        |                                       |
|------------------------|---------------------------------------|
| <b>Type</b>            | LT-HOB-SAW<br>Hobbing/tool holder saw |
| <b>Mounting</b>        | CYLINDRICAL SHANK 55                  |
| <b>Tool output</b>     | Shank kit Ø16-Ø22-Ø27                 |
| <b>Coolant</b>         | External coolant                      |
| <b>Max speed [rpm]</b> | in 6000 / out 2400                    |
| <b>Max torque [Nm]</b> | in 60 / out 150                       |
| <b>Ratio</b>           | 2,5:1                                 |
| <b>H [mm]</b>          | 90                                    |
| <b>H1 [mm]</b>         | 40                                    |
| <b>Accessories</b>     | N.A.                                  |
| <b>Notes</b>           | N.A.                                  |
| <b>Mounting tips</b>   | N.A.                                  |

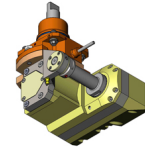

Always check live tool dimensions on the turret

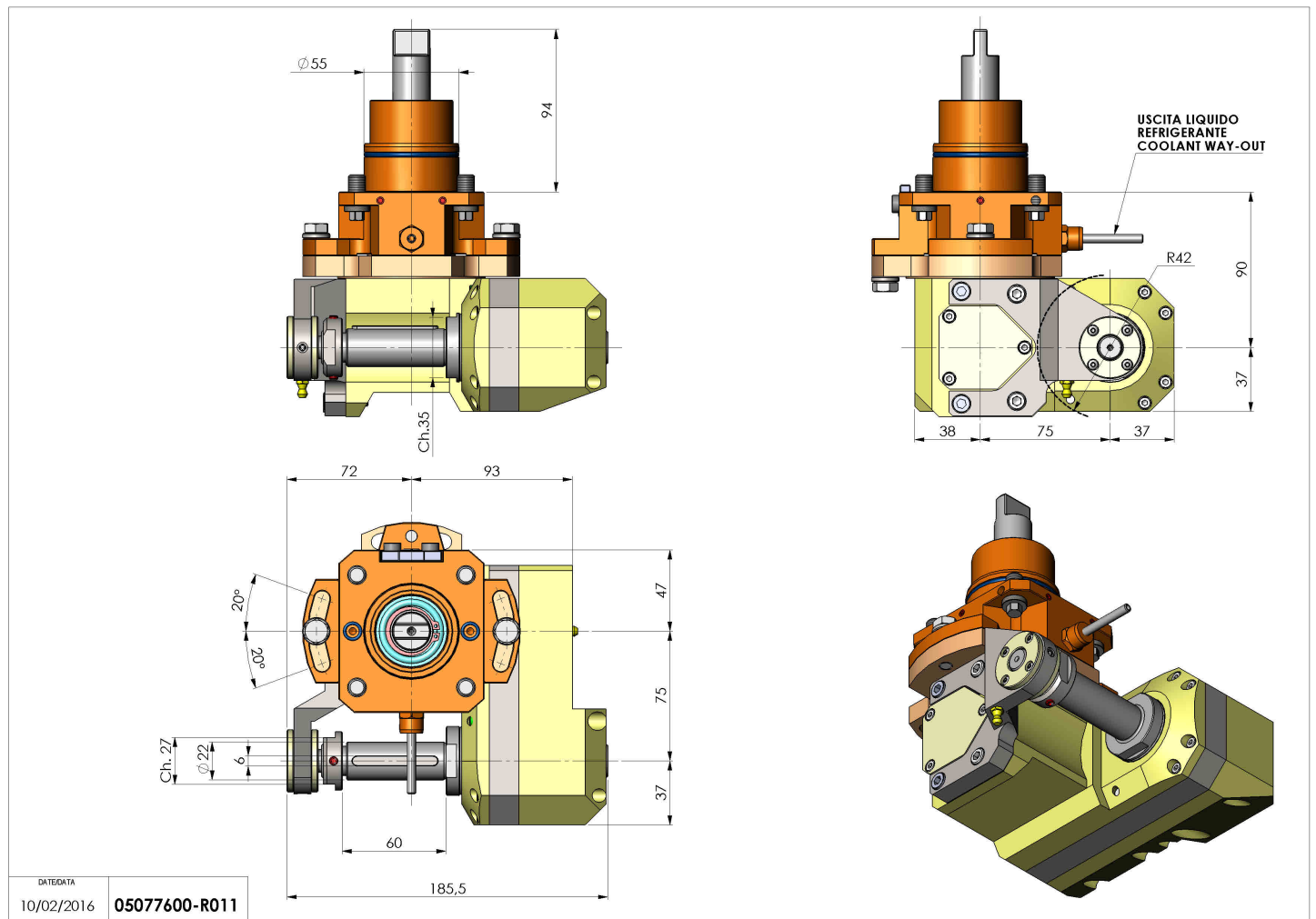

Subject to technical changes