

05076500 - LT-A D55 ER32 LR RF 2:1 H100BI

Type	LT-A Tool holder angle 90°
Mounting	CYLINDRICAL SHANK 55
Tool output	Collet nut ER 32
Coolant	Internal coolant
Direction of rotation	r1 ↻ r2 ↻
Max speed [rpm]	in 6000 / out 3000
Max torque [Nm]	in 70 / out 140
Ratio	2:1
H [mm]	100
H1 [mm]	38
Max pressure [bar]	20
Accessories	N.A.
Notes	N.A.
Mounting tips	Main and secondary spindle

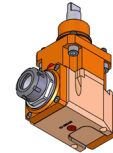

Always check live tool dimensions on the turret

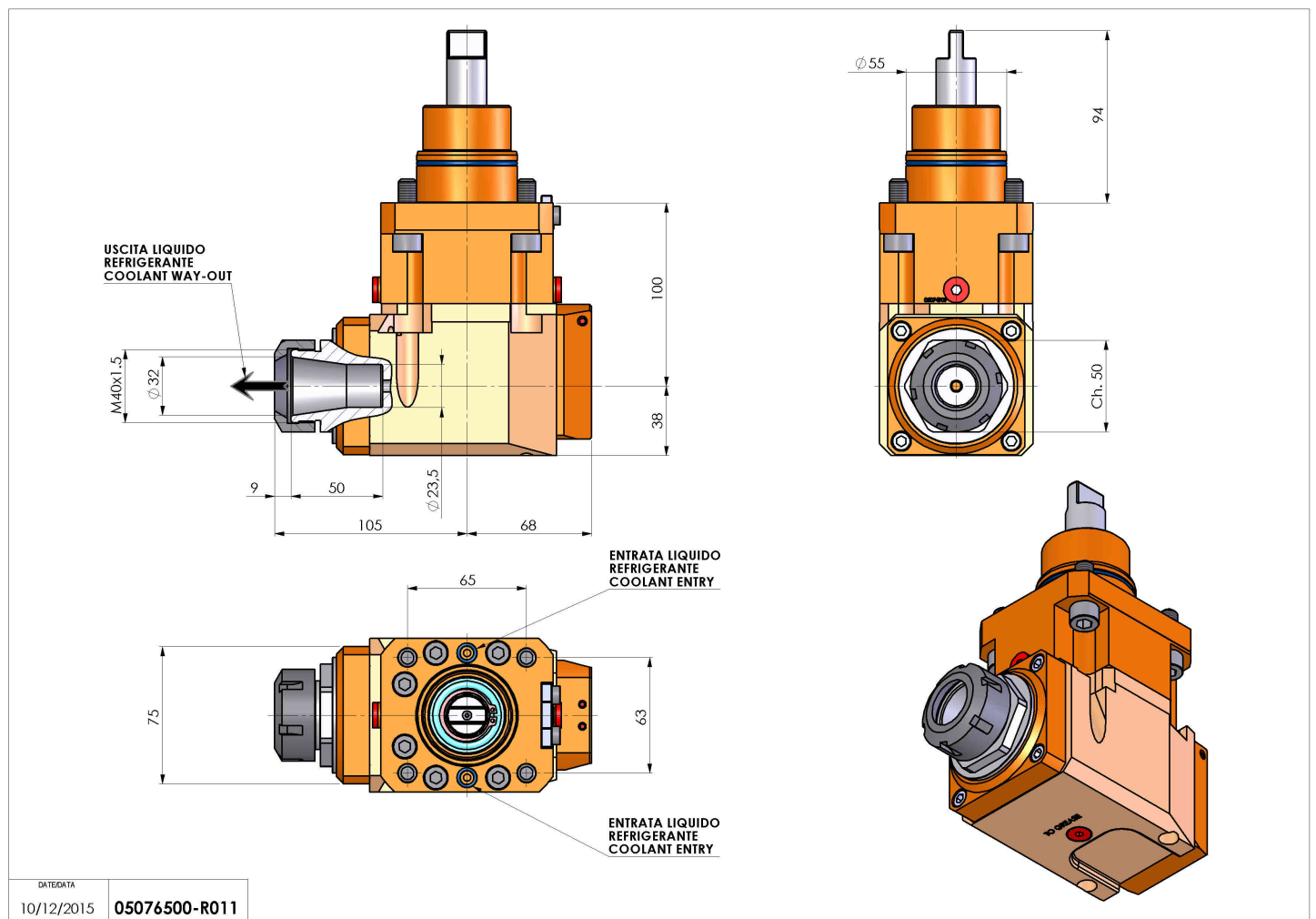

DATE/DATE	10/12/2015
	05076500-R011

Subject to technical changes