

05076400 - LT-A D55 ER32 LR 2:1 H70 BI

Type	LT-A Tool holder angle 90°
Mounting	CYLINDRICAL SHANK 55
Tool output	Collet nut ER 32
Coolant	External coolant
Direction of rotation	r1 ↻ r2 ↻
Max speed [rpm]	in 6000 / out 3000
Max torque [Nm]	in 70 / out 140
Ratio	2:1
H [mm]	70
H1 [mm]	38
Accessories	N.A.
Notes	N.A.
Mounting tips	Main and secondary spindle

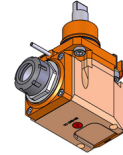

Always check live tool dimensions on the turret

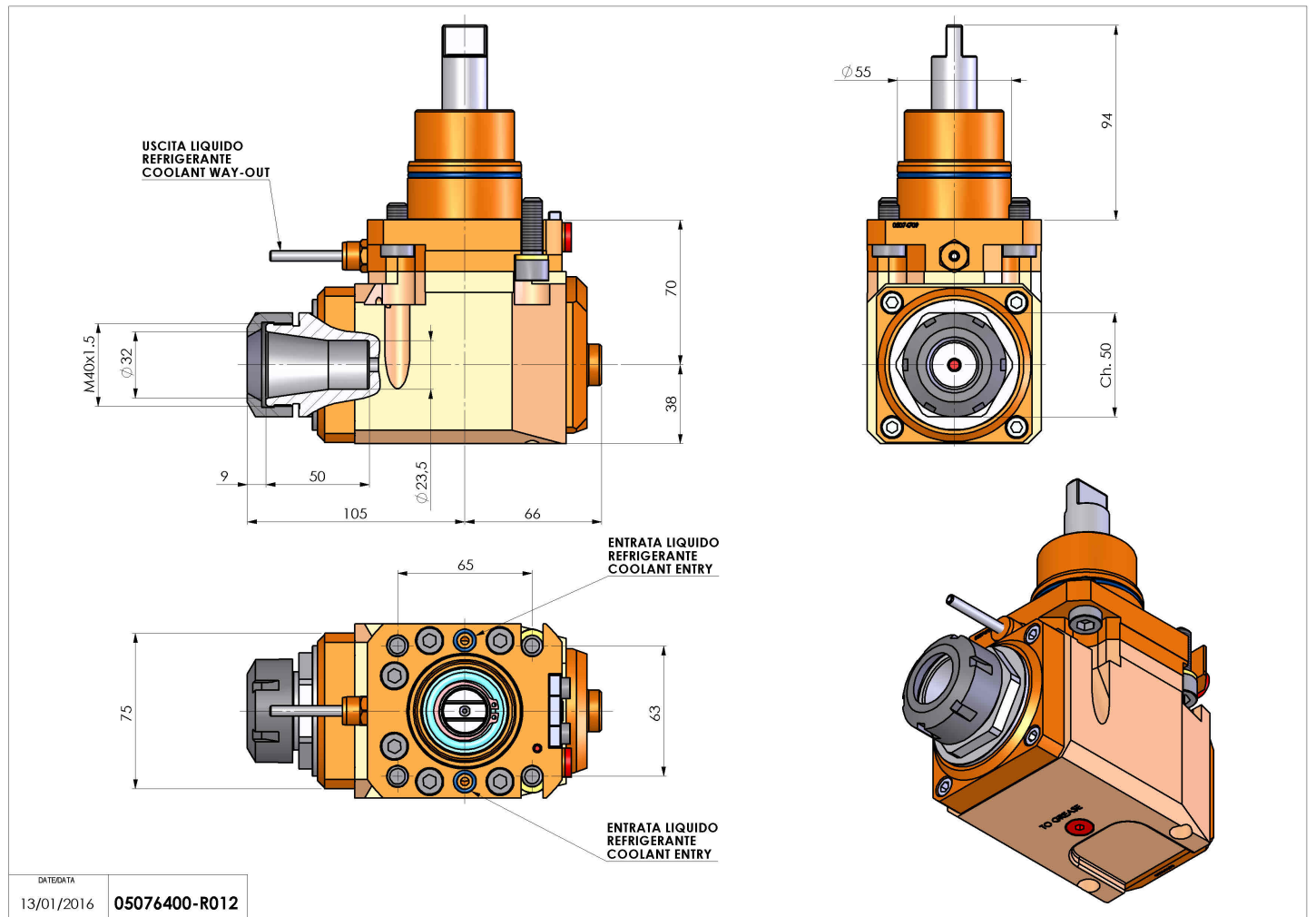

DATE/DATE	13/01/2016	05076400-R012
-----------	------------	---------------

Subject to technical changes