

05071900 - LT-S D40 P-FRE D16 H55 SPEC

Type	LT-S Tool holder straight
Mounting	CYLINDRICAL SHANK 40
Tool output	Shell-Mill DIN138 16
Coolant	External coolant
Direction of rotation	r1 r2
Max speed [rpm]	6000
Max torque [Nm]	25
Ratio	1:1
H [mm]	55
Accessories	N.A.
Notes	N.A.
Mounting tips	N.A.

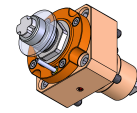

Always check live tool dimensions on the turret

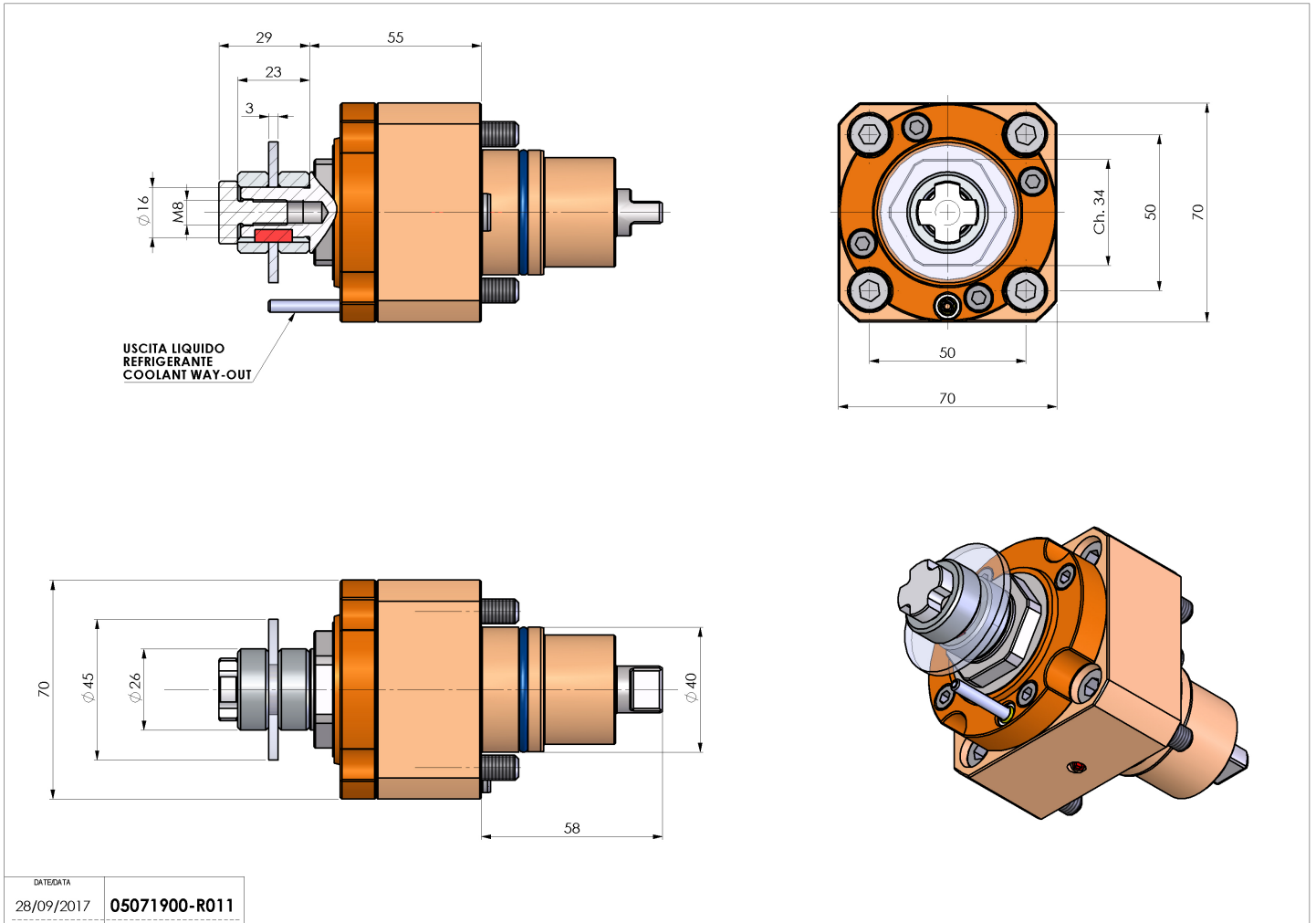

DATE/DATE	
28/09/2017	05071900-R011

Subject to technical changes