

05067400 - LT-S2 VDI30 ER11 I30 H85 1:10K

Type	LT-S2 Tool holder double straight
Mounting	VDI 30
Tool output	Collet nut ER 11
Coolant	External coolant
Direction of rotation	r1 ↻ r2 ↻ r3 ↻
Max speed [rpm]	6000
Max torque [Nm]	10
Ratio	1:1
H [mm]	85
Accessories	N.A.
Notes	N.A.
Mounting tips	N.A.

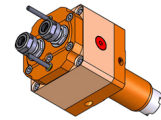

ATTENTION: CHECK THE ORIENTATION OF THE VDI TEETH

Always check live tool dimensions on the turret

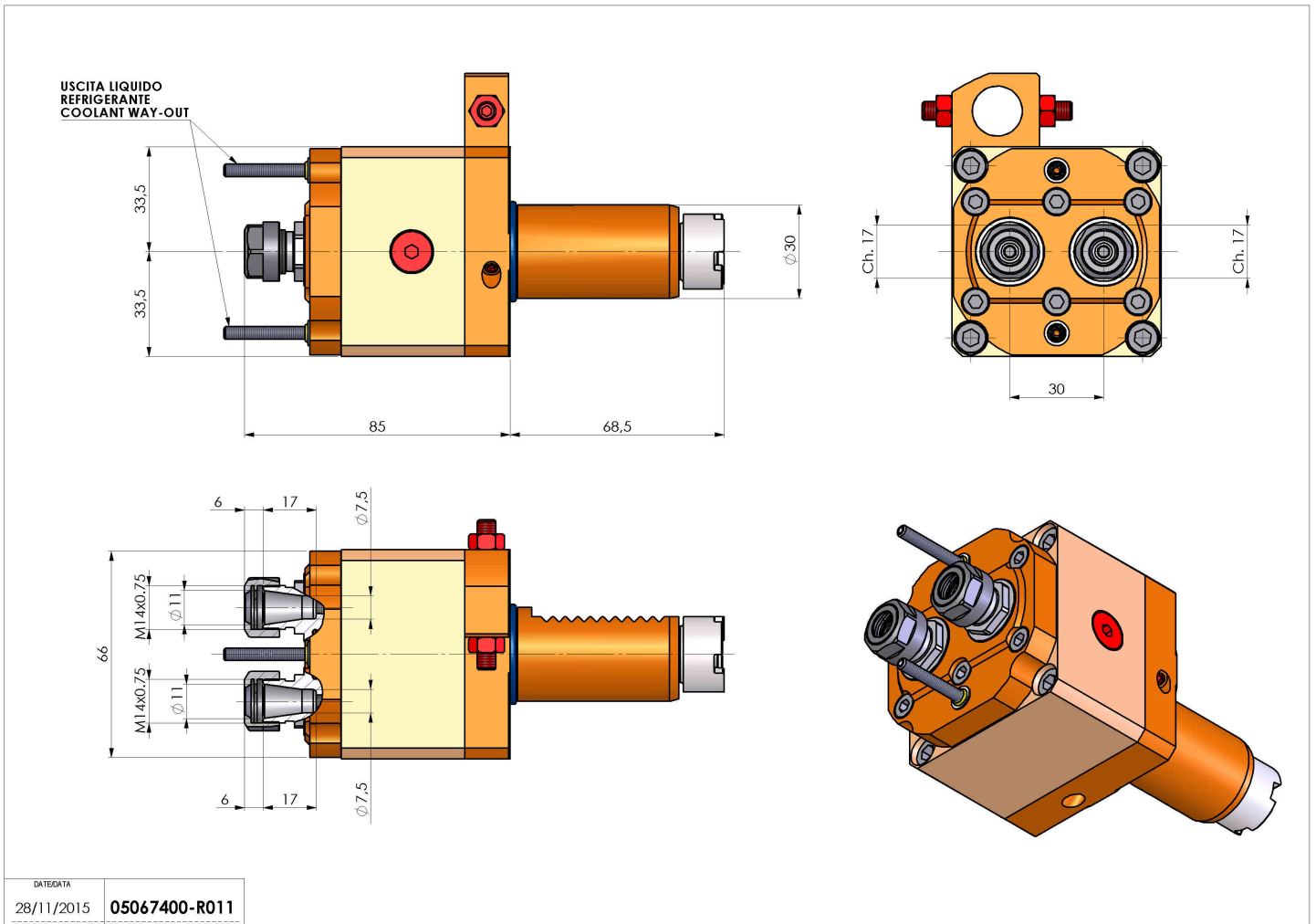

DATE/GRA	05067400-R011
28/11/2015	

Subject to technical changes