

05066700 - LT-A VDI30 ER25F L H90 OK

Type	LT-A Tool holder angle 90°
Mounting	VDI 30
Tool output	Collet nut ER 25 F - internal nut
Coolant	External coolant
Direction of rotation	r1 ↻ r2 ↻
Max speed [rpm]	6000
Max torque [Nm]	40
Ratio	1:1
H [mm]	90
H1 [mm]	32,5
Accessories	N.A.
Notes	N.A.
Mounting tips	Main spindle only

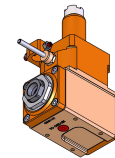

ATTENTION: CHECK THE ORIENTATION OF THE VDI TEETH

Always check live tool dimensions on the turret

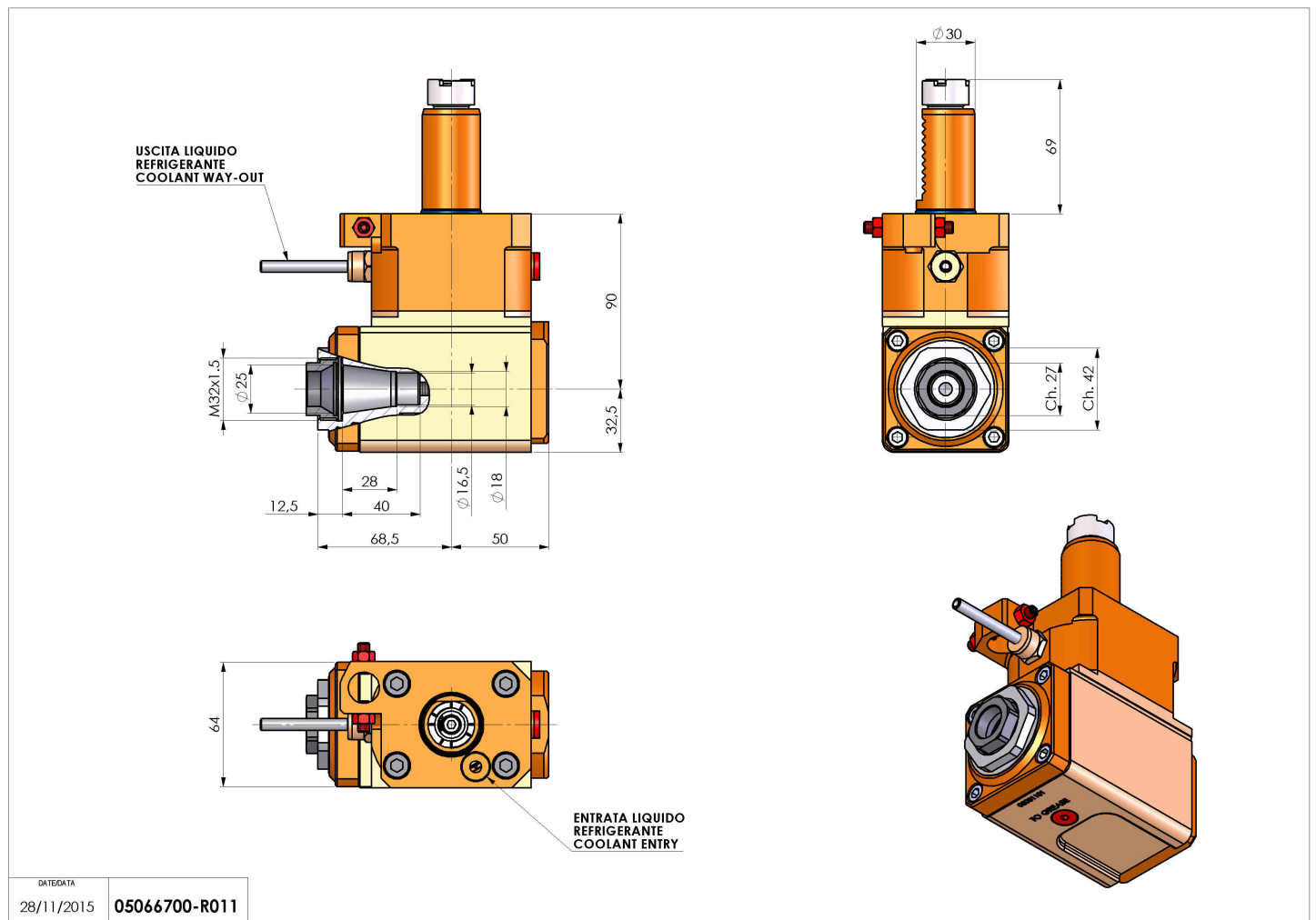

DATE/DATE	28/11/2015	05066700-R011
-----------	------------	---------------

Subject to technical changes