

05065100 - LT-T VDI30 ER16F H63-132 F OK

Type	LT-T Tool holder tiltable
Mounting	VDI 30
Tool output	Collet nut ER 16 F - internal nut
Coolant	External coolant
Direction of rotation	r1 r2
Max speed [rpm]	6000
Max torque [Nm]	10
Ratio	1:1
H [mm]	63-132
Accessories	N.A.
Notes	N.A.
Mounting tips	N.A.

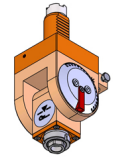

ATTENTION: CHECK THE ORIENTATION OF THE VDI TEETH

Always check live tool dimensions on the turret

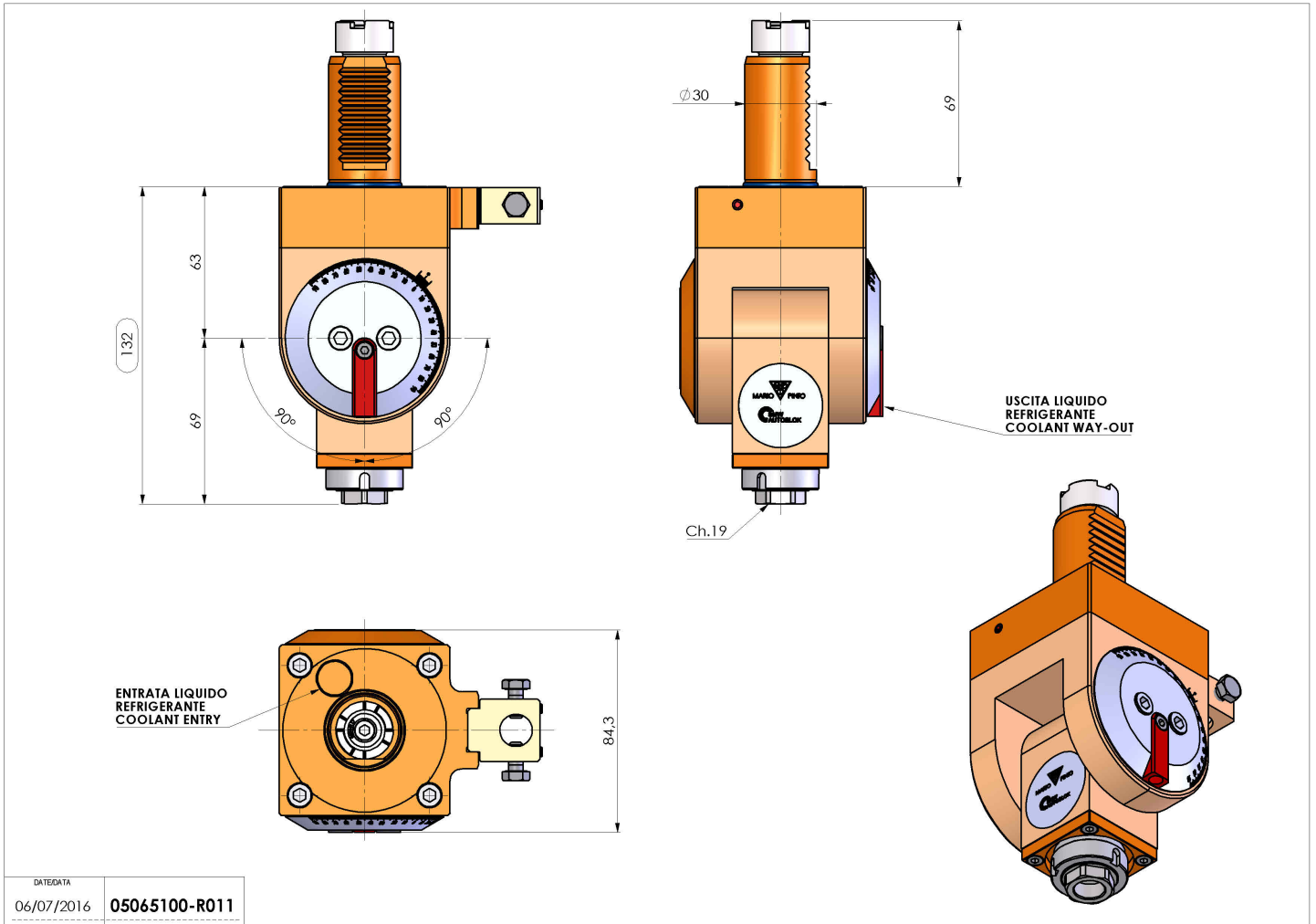

DATE/DATE: 06/07/2016
05065100-R011

Subject to technical changes