

## 05060900 - LT-HOB-SAW D60 2,5:1 H70

<b>Type</b>	LT-HOB-SAW Hobbing/tool holder saw
<b>Mounting</b>	CYLINDRICAL SHANK 60
<b>Tool output</b>	Shank kit Ø16-Ø22-Ø27
<b>Coolant</b>	External coolant
<b>Max speed [rpm]</b>	in 6000 / out 2400
<b>Max torque [Nm]</b>	in 32 / out 80
<b>Ratio</b>	2,5:1
<b>H [mm]</b>	70
<b>H1 [mm]</b>	40
<b>Accessories</b>	N.A.
<b>Notes</b>	N.A.
<b>Mounting tips</b>	Main spindle only

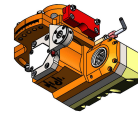

Always check live tool dimensions on the turret

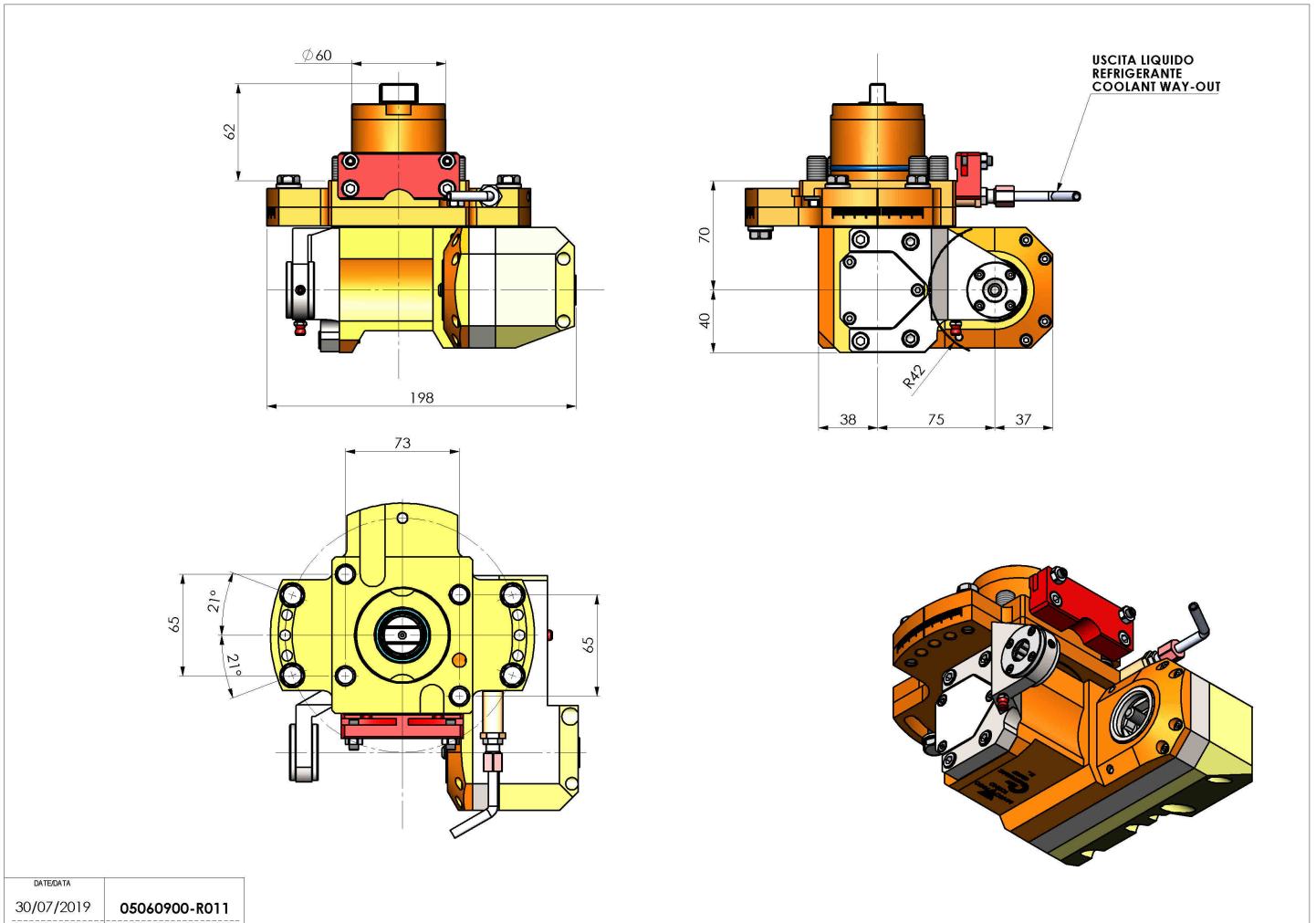

DATE/GRA	
30/07/2019	05060900-R011

**Subject to technical changes**