



05056100 - LT-S D40 ER32F OFS50 RF H80 MZ

Type	LT-S OFS Tool holder straight offset
Mounting	CYLINDRICAL SHANK 40
Tool output	Collet nut ER 32 F - internal nut
Coolant	Internal coolant
Offset [mm]	50
Direction of rotation	r1  r2 
Max speed [rpm]	6000
Max torque [Nm]	63
Ratio	1:1
H [mm]	80
Max pressure [bar]	20
Accessories	N.A.
Notes	N.A.
Mounting tips	N.A.



Always check live tool dimensions on the turret

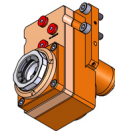
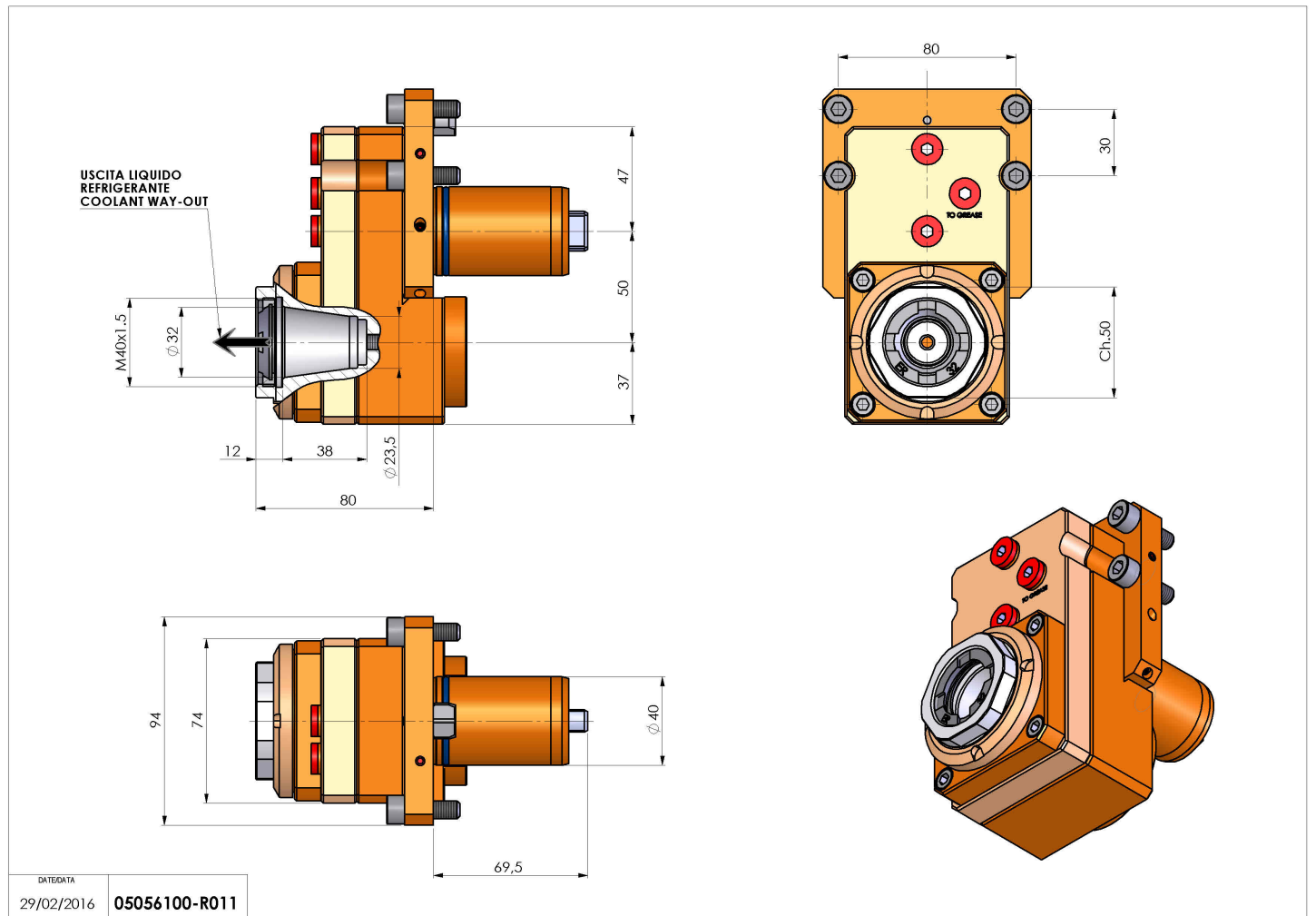

Subject to technical changes