

05054700 - LT-S VDI50 DIN27 OFS76 H121 MZ

Type	LT-S OFS Tool holder straight offset
Mounting	VDI 50
Tool output	Shell-Mill DIN138 27
Coolant	External coolant
Offset [mm]	76
Direction of rotation	r1 ↻ r2 ↻
Max speed [rpm]	6000
Max torque [Nm]	120
Ratio	1:1
H [mm]	121
Accessories	N.A.
Notes	N.A.
Mounting tips	N.A.

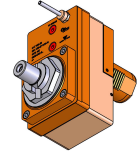

ATTENTION: CHECK THE ORIENTATION OF THE VDI TEETH

Always check live tool dimensions on the turret

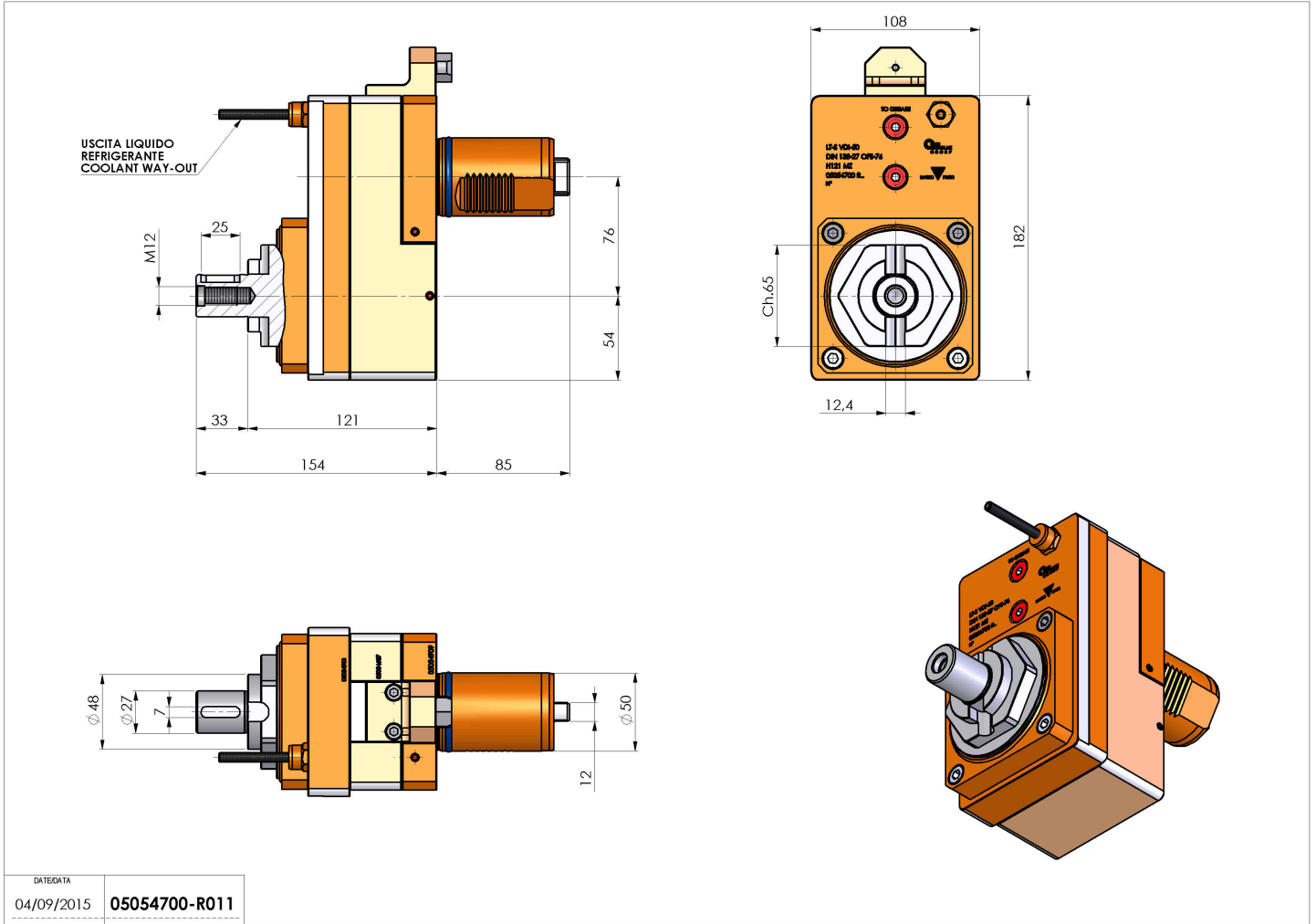

DATE/DATE	04/09/2015
05054700-R011	

Subject to technical changes