

05047200 - LT-S D60 ER32F OF76RF 1:1 H106

Type	LT-S OFS Tool holder straight offset
Mounting	CYLINDRICAL SHANK 60
Tool output	Collet nut ER 32 F - internal nut
Coolant	Internal coolant
Offset [mm]	76
Direction of rotation	r1 ↻ r2 ↻
Max speed [rpm]	6000
Max torque [Nm]	40
Ratio	1:1
H [mm]	106
Max pressure [bar]	20
Accessories	N.A.
Notes	N.A.
Mounting tips	Main spindle only

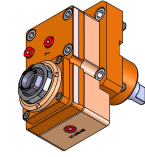

Always check live tool dimensions on the turret

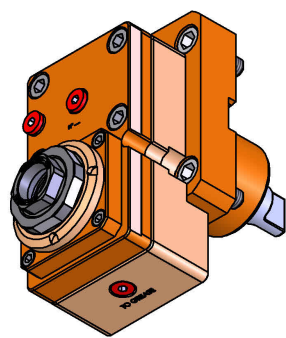
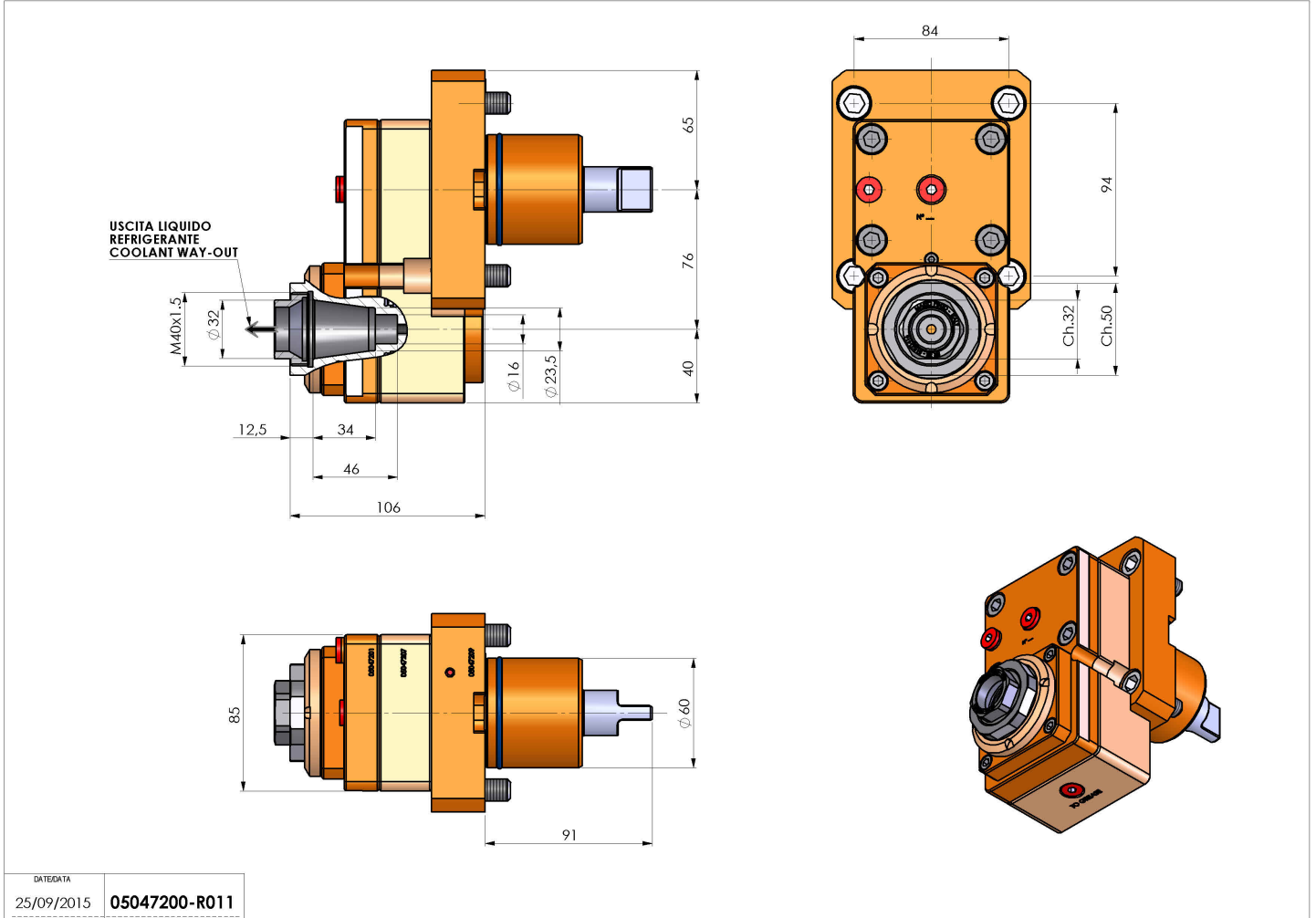

DATE/DATE: 25/09/2015 05047200-R011

Subject to technical changes