

# 05030700 - LT-A D60 ER32 R H90 TW

Type	LT-A Tool holder angle 90°
Mounting	CYLINDRICAL SHANK 60
Tool output	Collet nut ER 32
Coolant	External coolant
Direction of rotation	r1 ↻ r2 ↻
Max speed [rpm]	6000
Max torque [Nm]	63
Ratio	1:1
H [mm]	90
H1 [mm]	37
Accessories	N.A.
Notes	N.A.
Mounting tips	Secondary spindle only

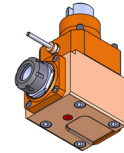

Always check live tool dimensions on the turret

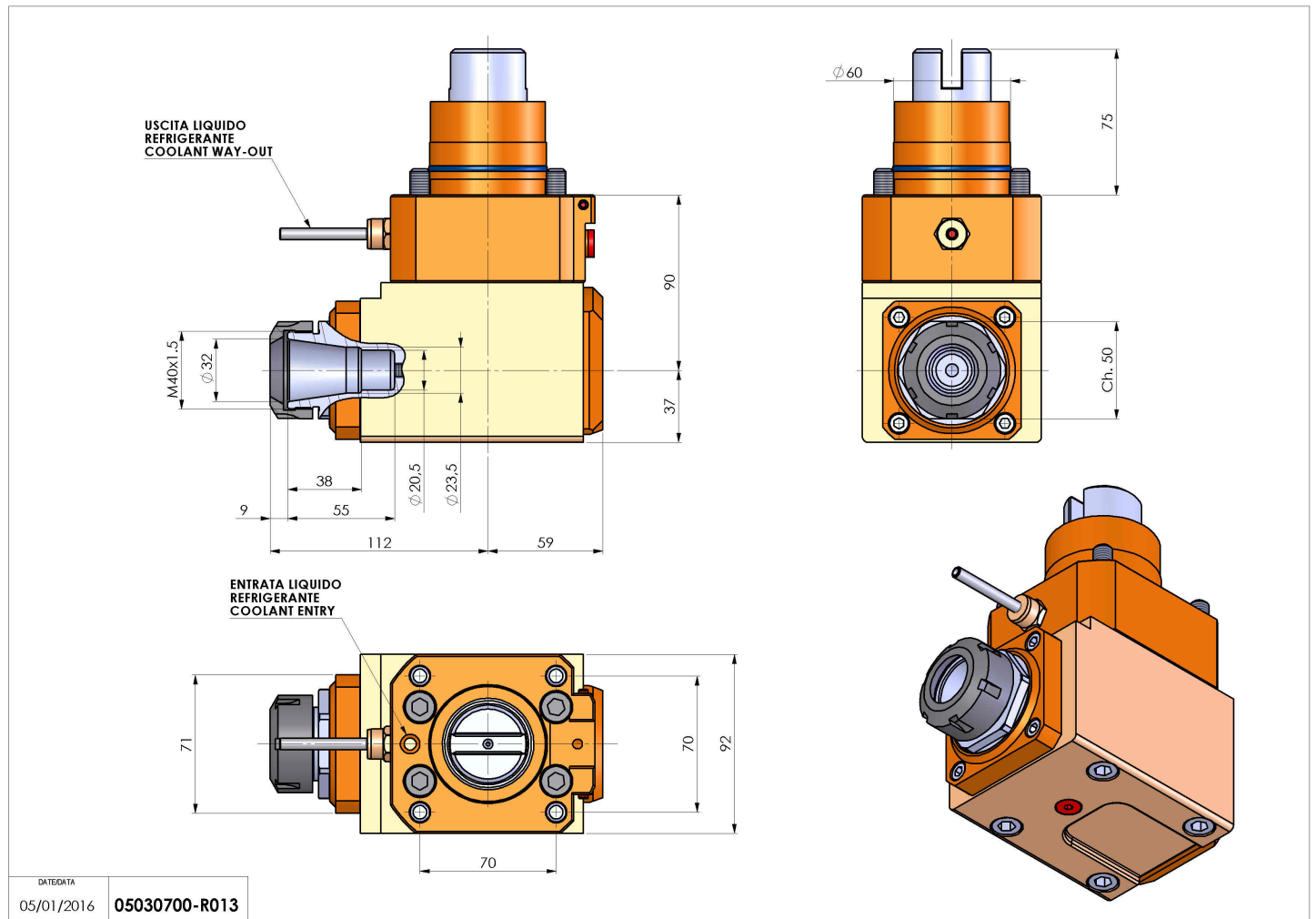

DATE/DATA  
05/01/2016 05030700-R013

Subject to technical changes