

05030500 - LT-A D60 ER32 L RF H90 TW

Type	LT-A Tool holder angle 90°
Mounting	CYLINDRICAL SHANK 60
Tool output	Collet nut ER 32
Coolant	Internal coolant
Direction of rotation	r1 ↻ r2 ↻
Max speed [rpm]	6000
Max torque [Nm]	63
Ratio	1:1
H [mm]	90
H1 [mm]	37
Max pressure [bar]	20
Accessories	N.A.
Notes	
Mounting tips	N.A.

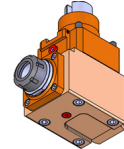

Always check live tool dimensions on the turret

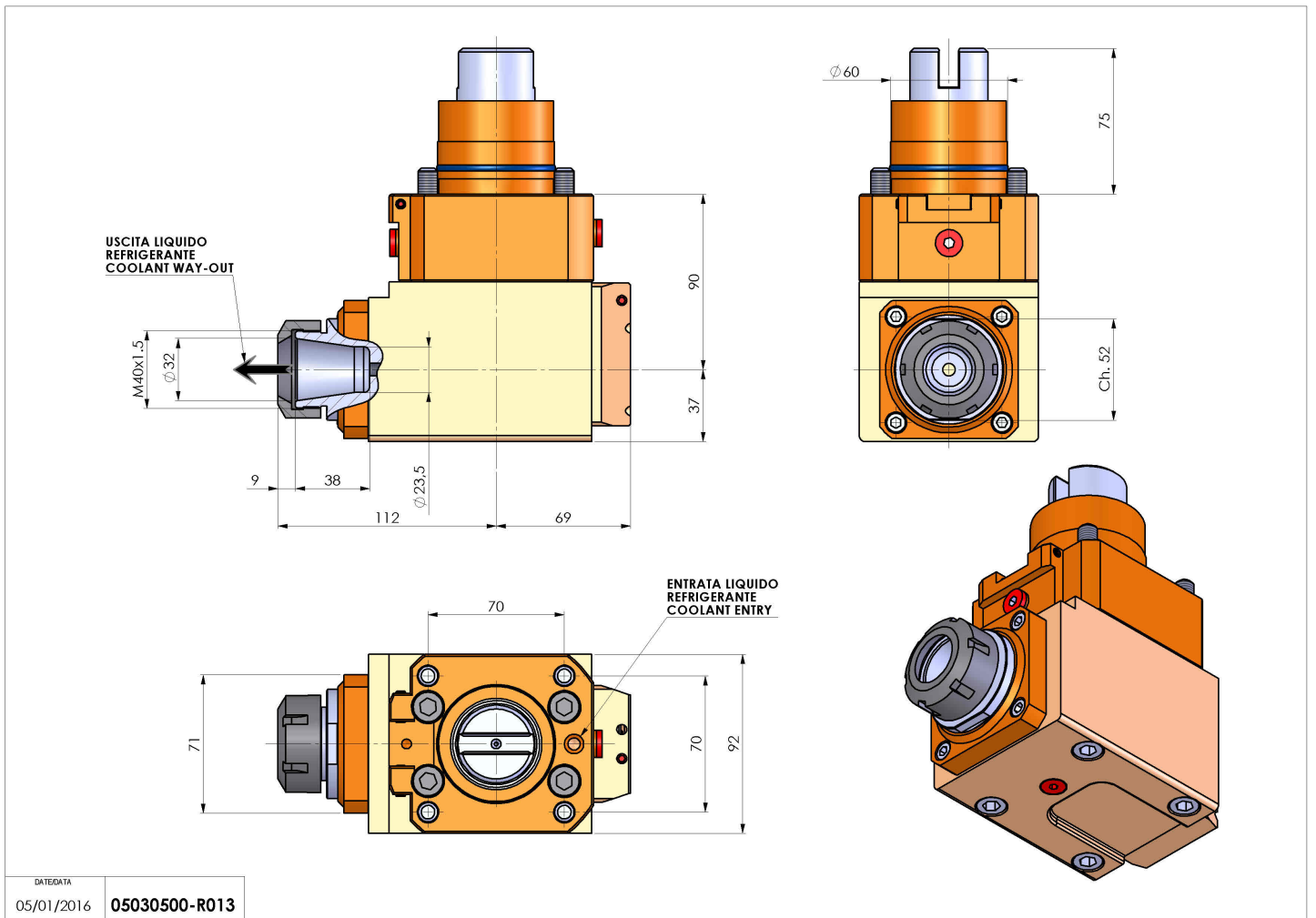

DATE/DATE
05/01/2016 05030500-R013

Subject to technical changes