

05027200 - LTS D30 ER20F OFS78 RF1:3H88TZ

Type	LT-S OFS Tool holder straight offset
Mounting	CYLINDRICAL SHANK 30
Tool output	Collet nut ER 20 F - internal nut
Coolant	Internal coolant
Offset [mm]	78
Direction of rotation	r1 r2
Max speed [rpm]	in 5000 / out 15000
Max torque [Nm]	in 50 / out 14
Ratio	1:3
H [mm]	88
Max pressure [bar]	20
Accessories	N.A.
Notes	N.A.
Mounting tips	N.A.

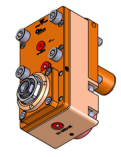

Always check live tool dimensions on the turret

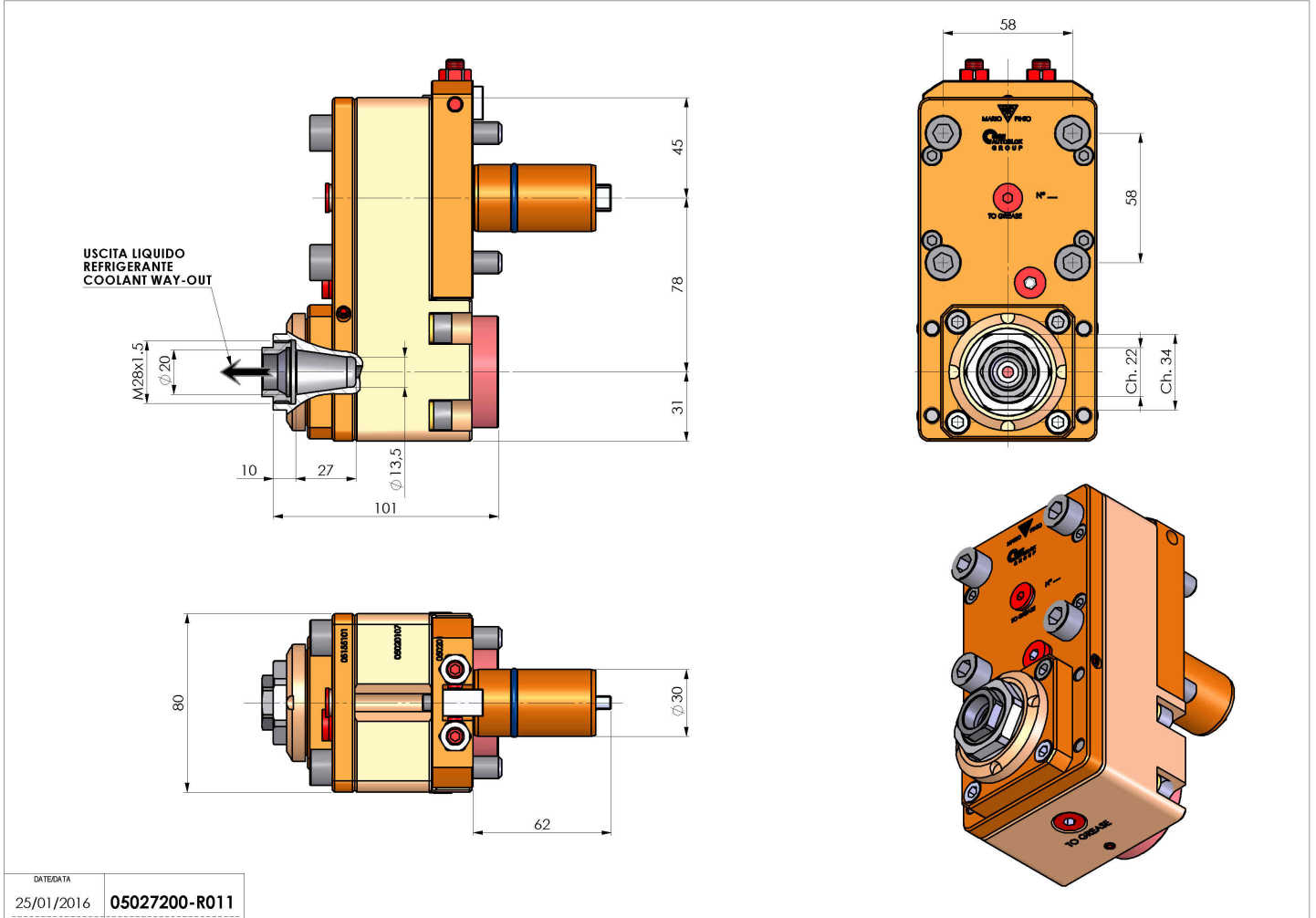

DATE/DATE	
25/01/2016	05027200-R011

Subject to technical changes