

05516400 - LT-A BMT75 BD WELDON40 RF H60

Type	LT-A Tool holder angle 90°
Mounting	BMT 75 BIG DRIVE
Tool output	Weldon 40 DIN1835B
Coolant	Internal coolant
Direction of rotation	r1 ↻ r2 ↻
Max speed [rpm]	4000
Max torque [Nm]	80
Ratio	1:1
H [mm]	60
H1 [mm]	43
Max pressure [bar]	20
Accessories	N.A.
Notes	N.A.
Mounting tips	Main and secondary spindle

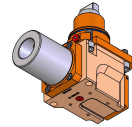

Always check live tool dimensions on the turret

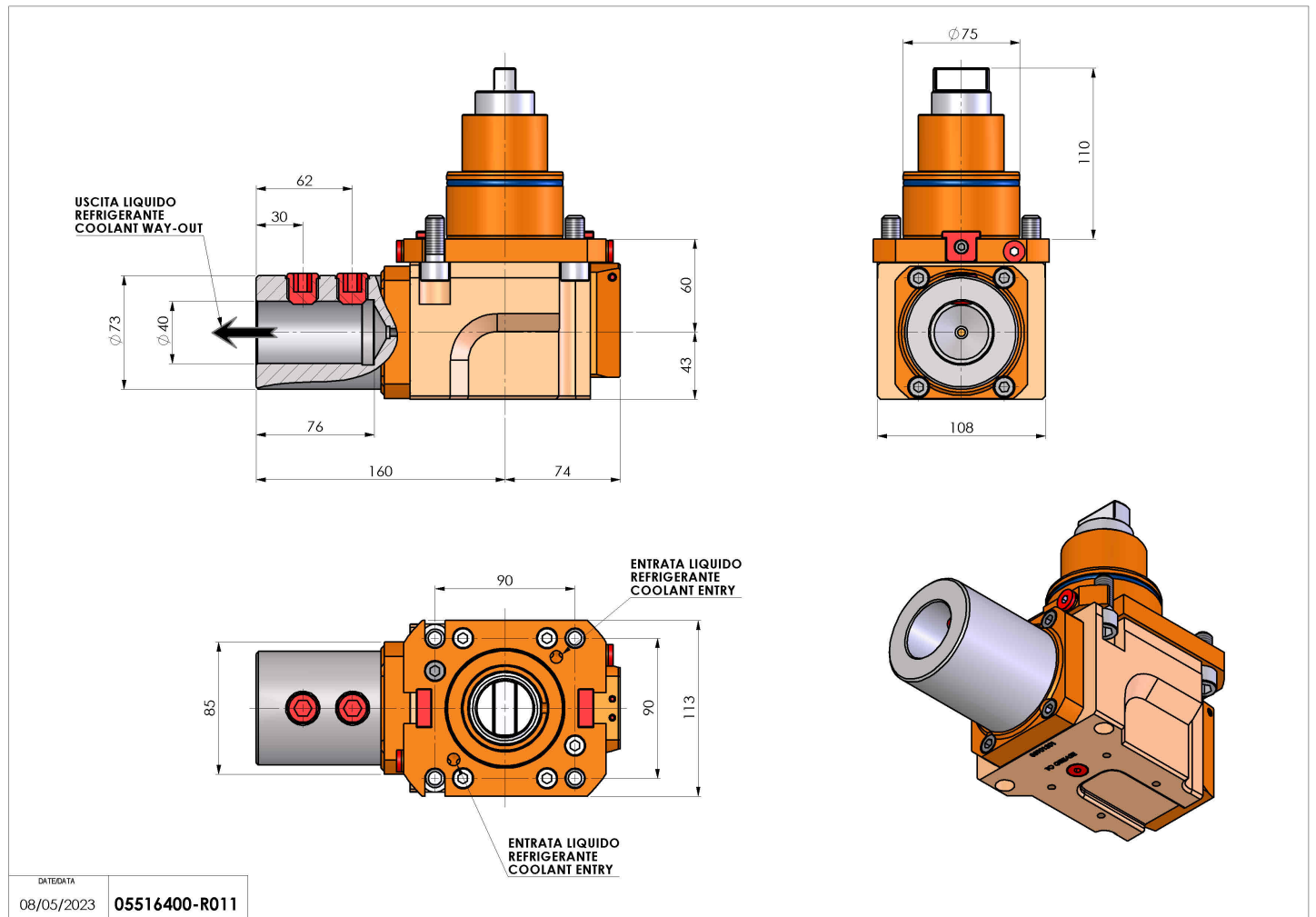

Subject to technical changes