

05516100 - LT-A ST-65 BMT75 BD C16 CR-AY H110

Type	LT-A ST Slotting tool 90°
Mounting	BMT 75 BIG DRIVE
Tool output	Tool diameter 16
Coolant	External coolant
Max speed [rpm]	700
Max torque [Nm]	17.5
Ratio	1:1
Y axis adjustment	SI
Feed pushing [N]	1000
Stroke [mm]	65
Work stroke [mm]	60
Y axis adjust. [mm]	±0,4
H [mm]	110
Accessories	N.A.
Notes	N.A.
Mounting tips	Main and secondary spindle

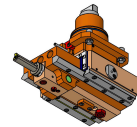

Always check live tool dimensions on the turret

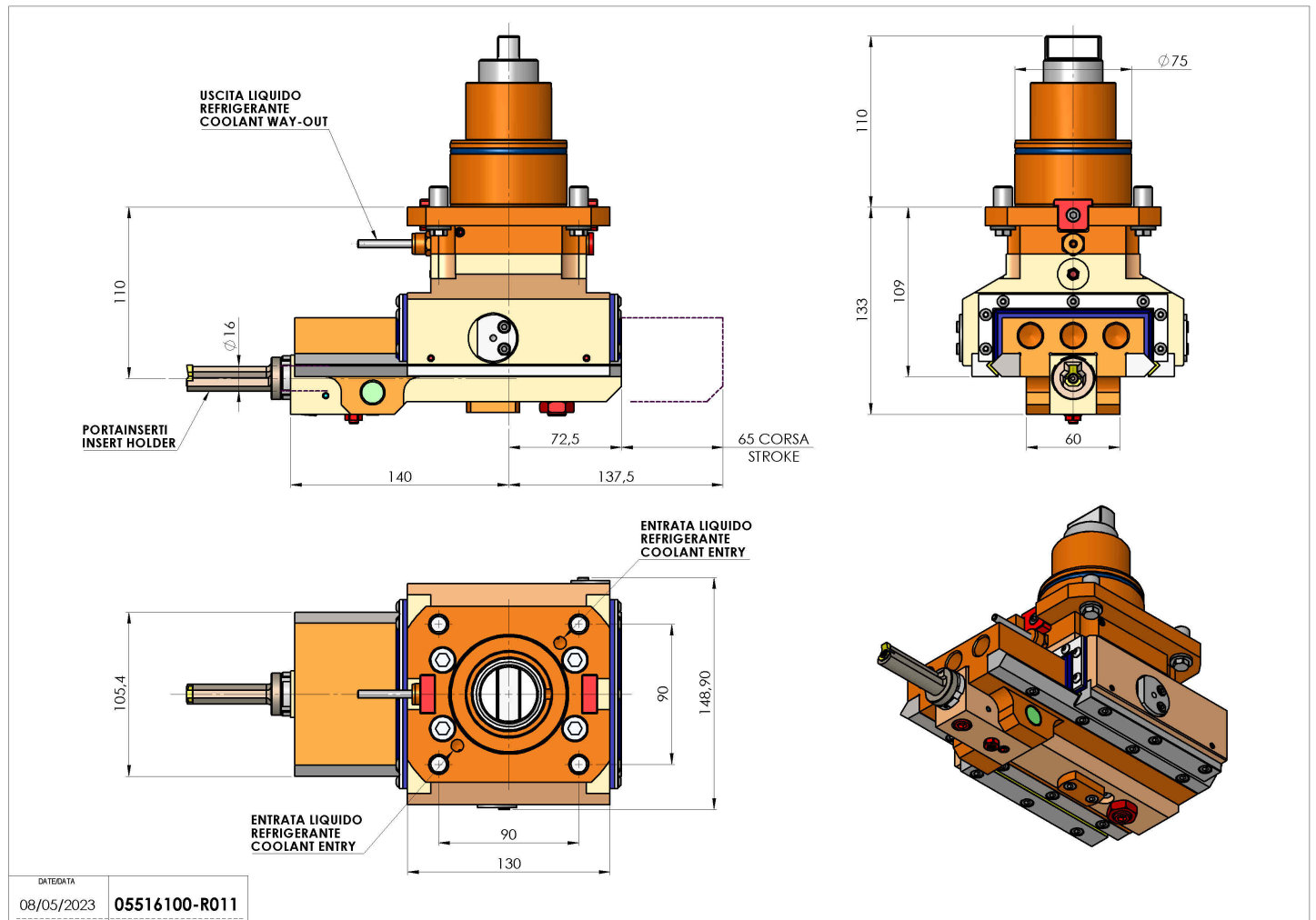

DATE DATA
08/05/2023 **05516100-R011**

Subject to technical changes