



05515700 - LT-A BMT75 BD HSK63 LR HRF H90

Type	LT-A Tool holder angle 90°
Mounting	BMT 75 BIG DRIVE
Tool output	Quick Change HSK63
Coolant	HRF Internal coolant
Direction of rotation	r1  r2 
Max speed [rpm]	4000
Max torque [Nm]	80
Ratio	1:1
H [mm]	90
H1 [mm]	43
Max pressure [bar]	80
Accessories	N.A.
Notes	N.A.
Mounting tips	Main and secondary spindle



Always check live tool dimensions on the turret

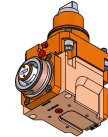
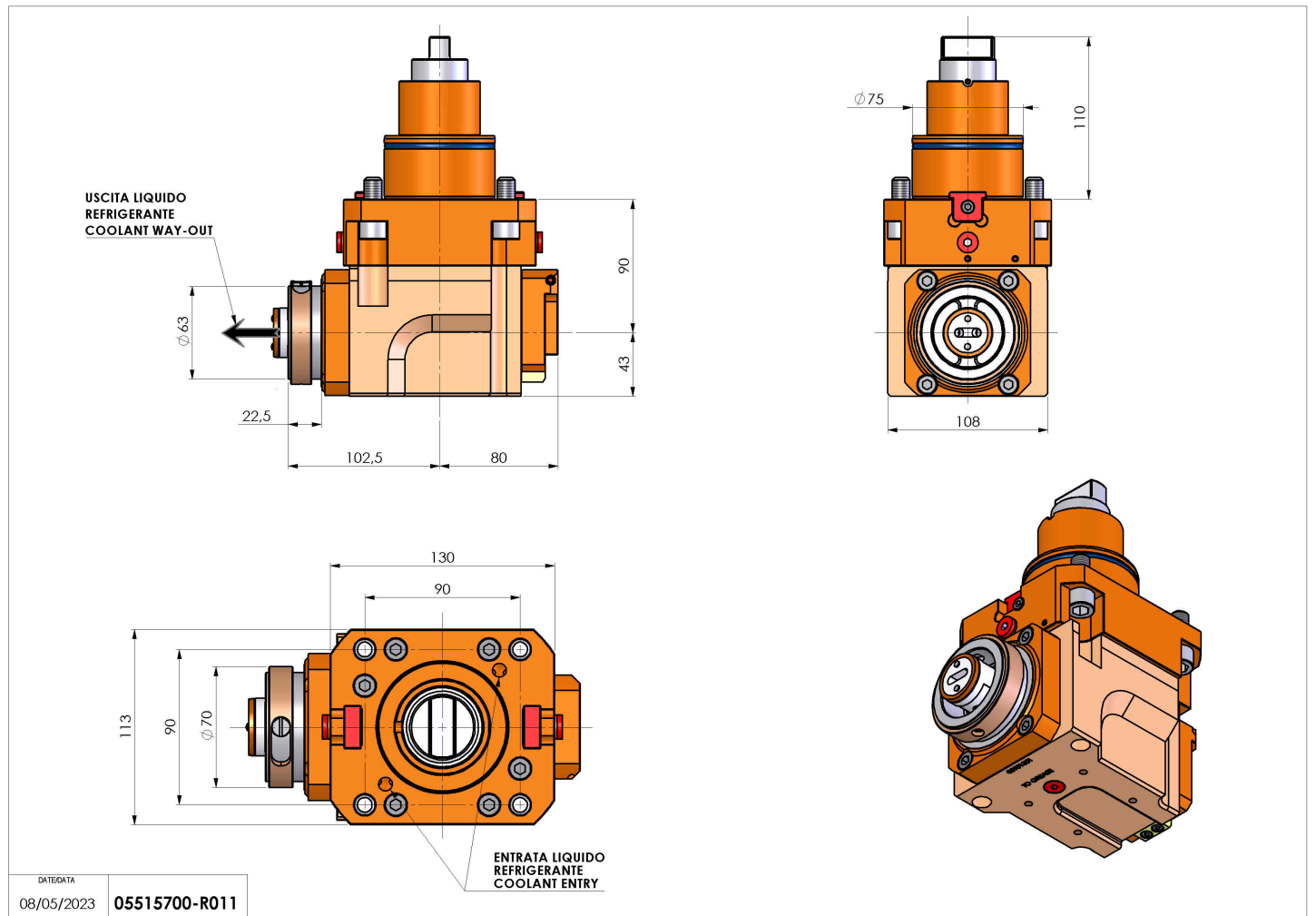

Subject to technical changes