

05511900 - LT-A BMT75 BD C50 L-R HRF H90

Type	LT-A Tool holder angle 90°
Mounting	BMT 75 BIG DRIVE
Tool output	Polygonal shank C50 ISO 26623-1
Coolant	HRF Internal coolant
Direction of rotation	r1 ↻ r2 ↻
Max speed [rpm]	6000
Max torque [Nm]	100
Ratio	1:1
H [mm]	90
H1 [mm]	54
Max pressure [bar]	80
Accessories	N.A.
Notes	N.A.
Mounting tips	Main and secondary spindle

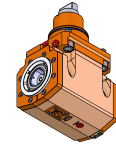

Always check live tool dimensions on the turret

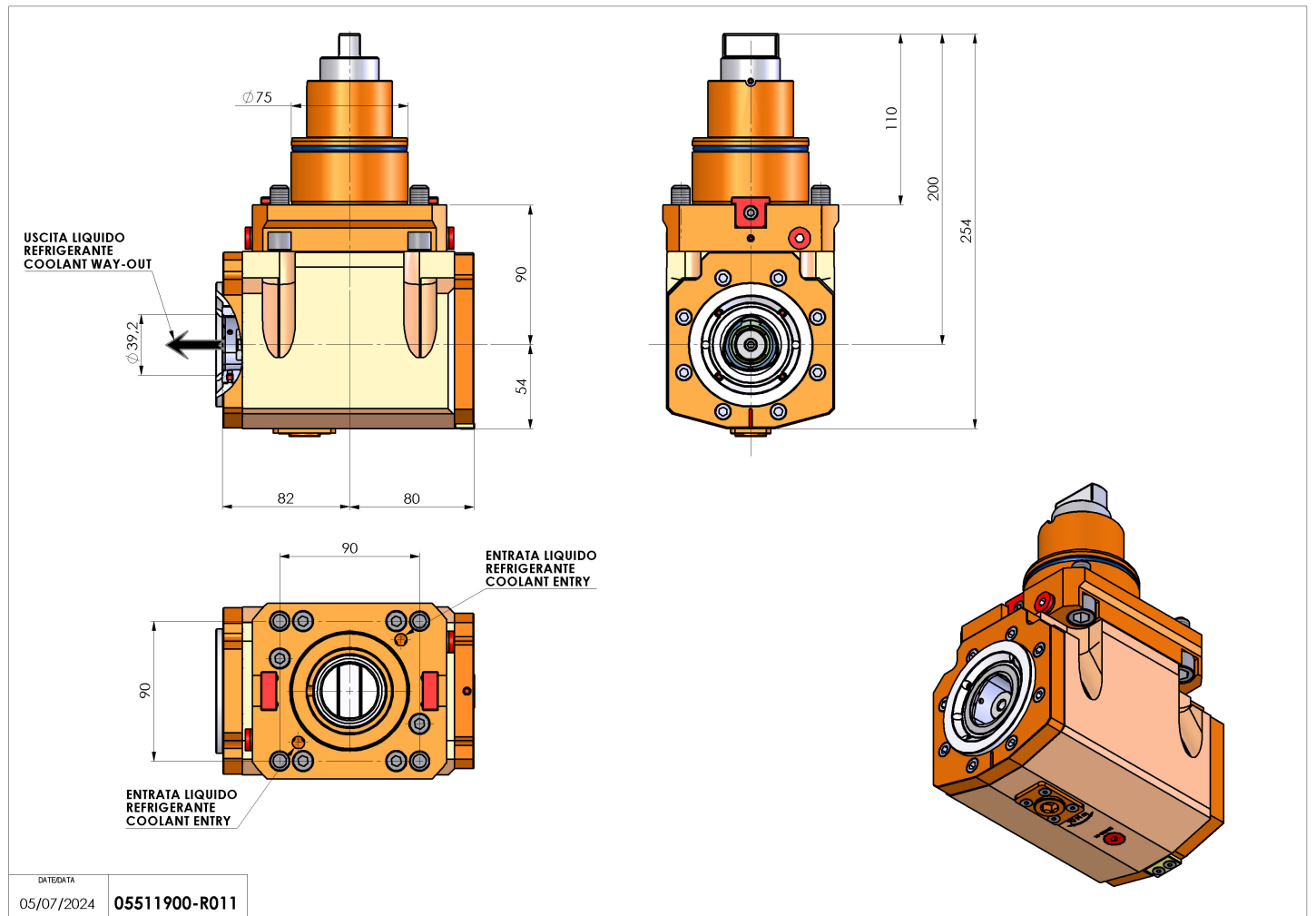

Subject to technical changes