

05485200 - LT-A VDI40 HSK63 R HRF H110

Type	LT-A Tool holder angle 90°
Mounting	VDI 40
Tool output	Quick Change HSK63
Coolant	HRF Internal coolant
Direction of rotation	r1 ↻ r2 ↻
Max speed [rpm]	4000
Max torque [Nm]	45
Ratio	1:1
H [mm]	110
H1 [mm]	43
Max pressure [bar]	80
Accessories	N.A.
Notes	N.A.
Mounting tips	N.A.

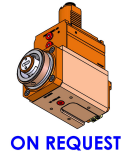

ATTENTION: CHECK THE ORIENTATION OF THE VDI TEETH

Always check live tool dimensions on the turret

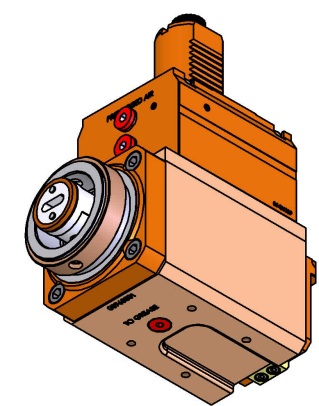
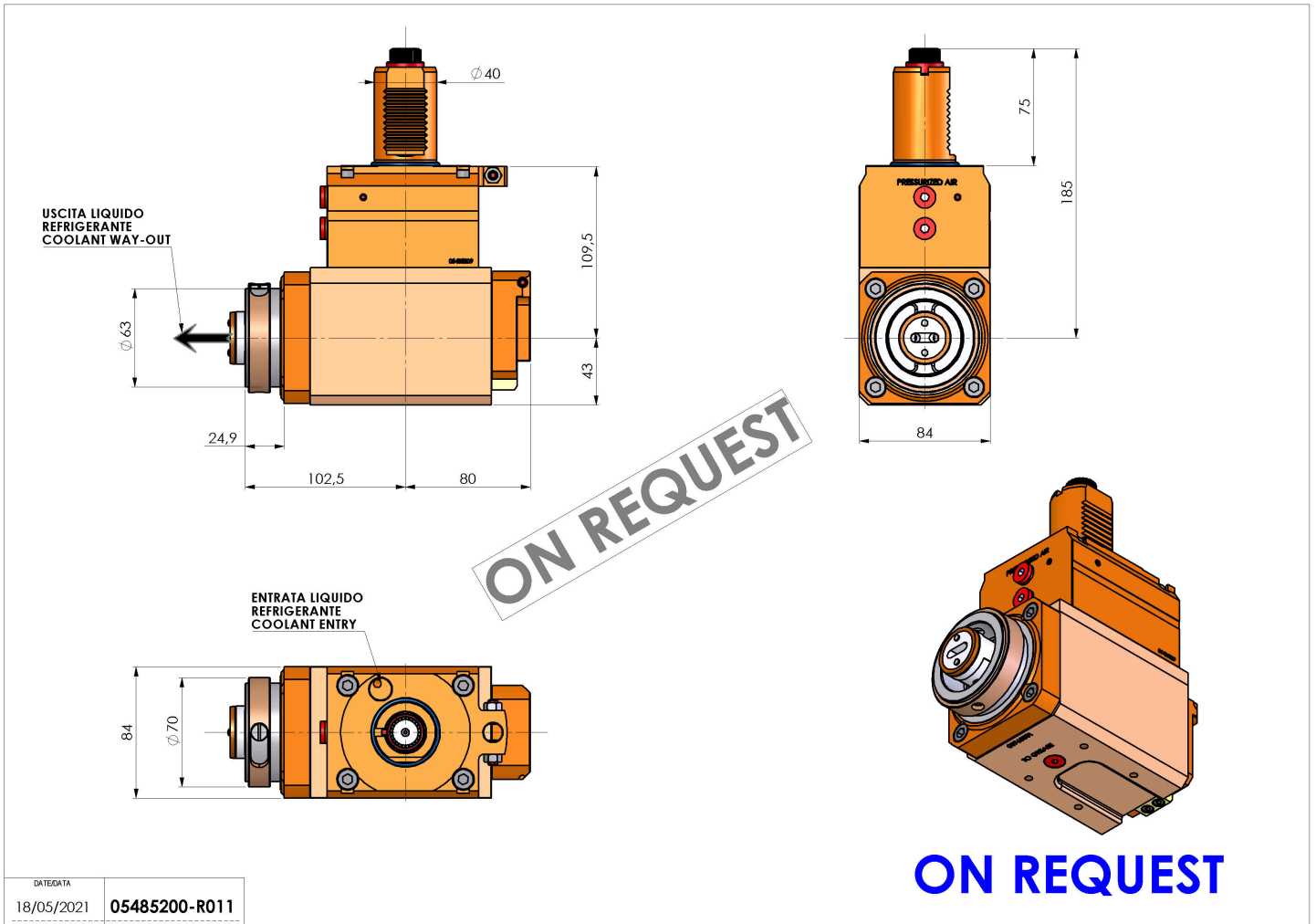

DATE/DATE	18/05/2021	05485200-R011
-----------	------------	---------------

Subject to technical changes