

05483300 - LT-A VDI40 DX-SX ER40F HRF H100

Type	LT-A Tool holder angle 90°
Mounting	VDI 40
Tool output	Collet nut ER 40 F - internal nut
Coolant	HRF Internal coolant
Direction of rotation	r1 r2
Max speed [rpm]	8000
Max torque [Nm]	80
Ratio	1:1
H [mm]	100
H1 [mm]	43
Max pressure [bar]	80
Accessories	N.A.
Notes	N.A.
Mounting tips	N.A.

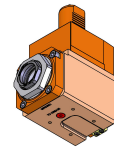

ATTENTION: CHECK THE ORIENTATION OF THE VDI TEETH

Always check live tool dimensions on the turret

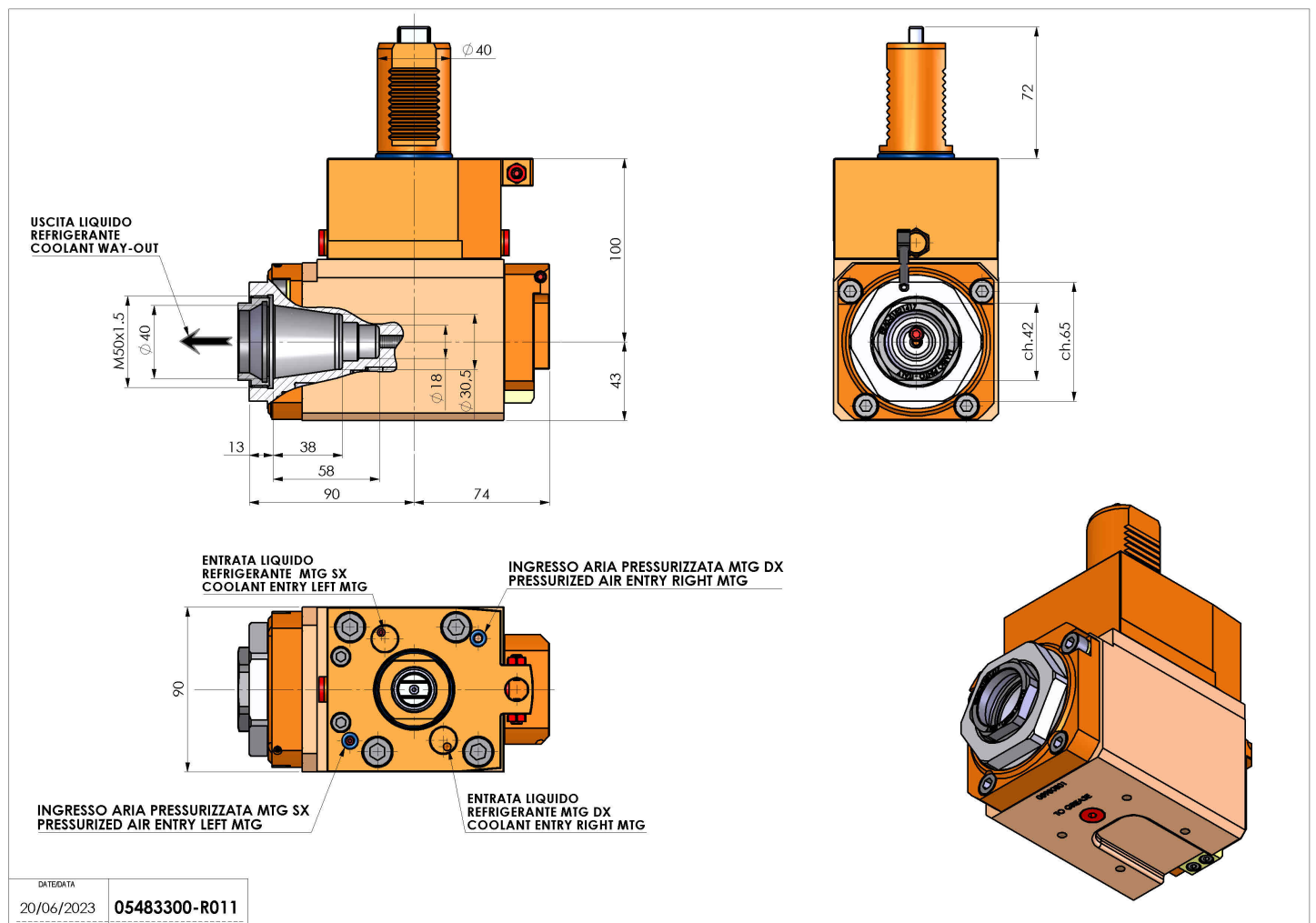

Subject to technical changes