



# 05483100 - LT-A VDI40 DX HSK40 HRF H100

Type	LT-A Tool holder angle 90°
Mounting	VDI 40
Tool output	Quick Change HSK40
Coolant	HRF Internal coolant
Direction of rotation	r1  r2 
Max speed [rpm]	8000
Max torque [Nm]	80
Ratio	1:1
H [mm]	100
H1 [mm]	38
Max pressure [bar]	80
Accessories	N.A.
Notes	N.A.
Mounting tips	N.A.

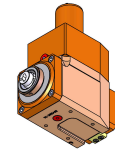

**ATTENTION: CHECK THE ORIENTATION OF THE VDI TEETH**

Always check live tool dimensions on the turret

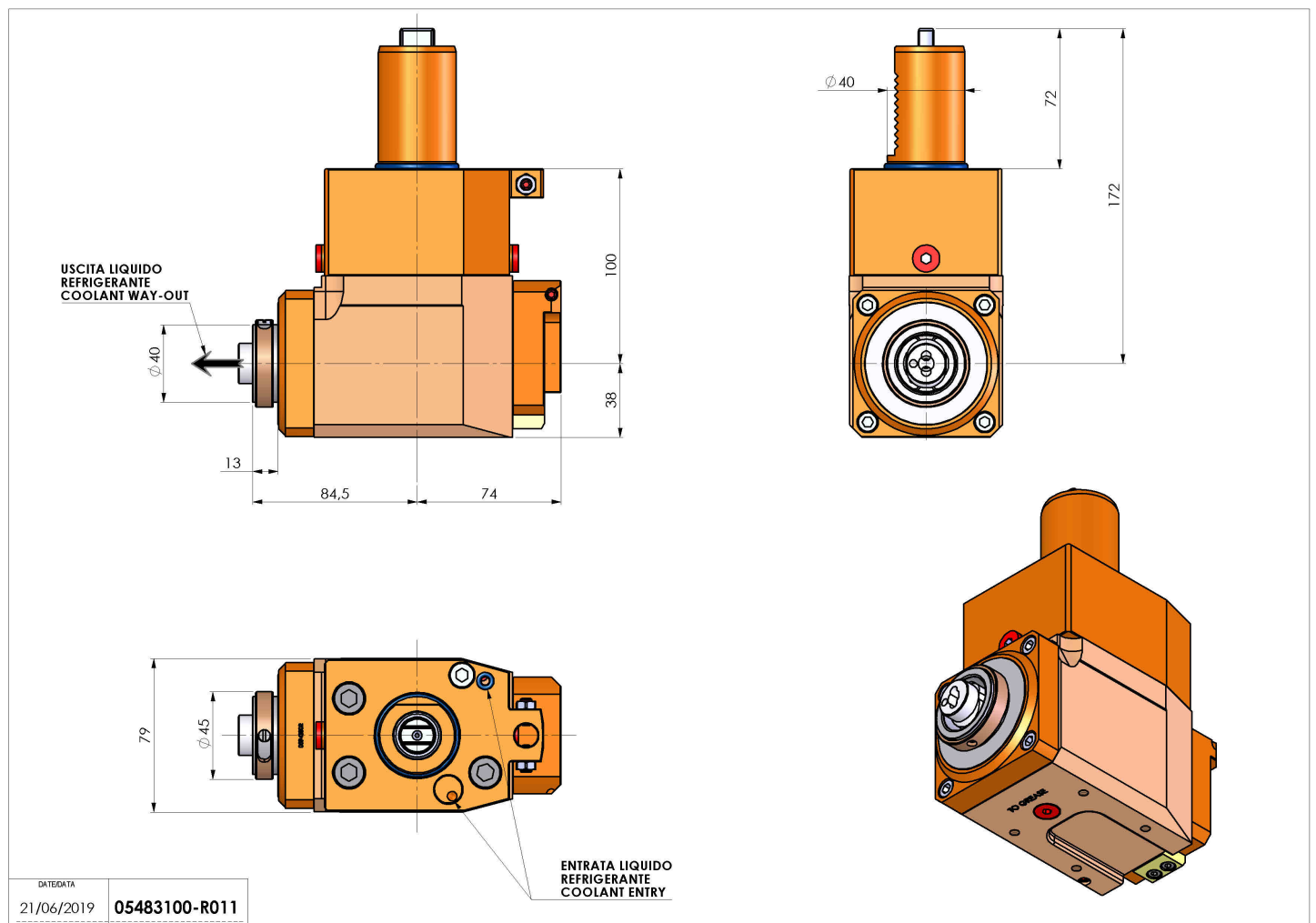

DATE/GATA  
21/06/2019 **05483100-R011**

Subject to technical changes