

05482500 - LT-A VDI40 DX WELDON20 RF H100

Type	LT-A Tool holder angle 90°
Mounting	VDI 40
Tool output	Weldon 20 DIN1835B
Coolant	Internal coolant
Direction of rotation	r1 ↻ r2 ↻
Max speed [rpm]	8000
Max torque [Nm]	80
Ratio	1:1
H [mm]	100
H1 [mm]	38
Max pressure [bar]	20
Accessories	N.A.
Notes	N.A.
Mounting tips	N.A.

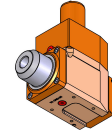

ATTENTION: CHECK THE ORIENTATION OF THE VDI TEETH

Always check live tool dimensions on the turret

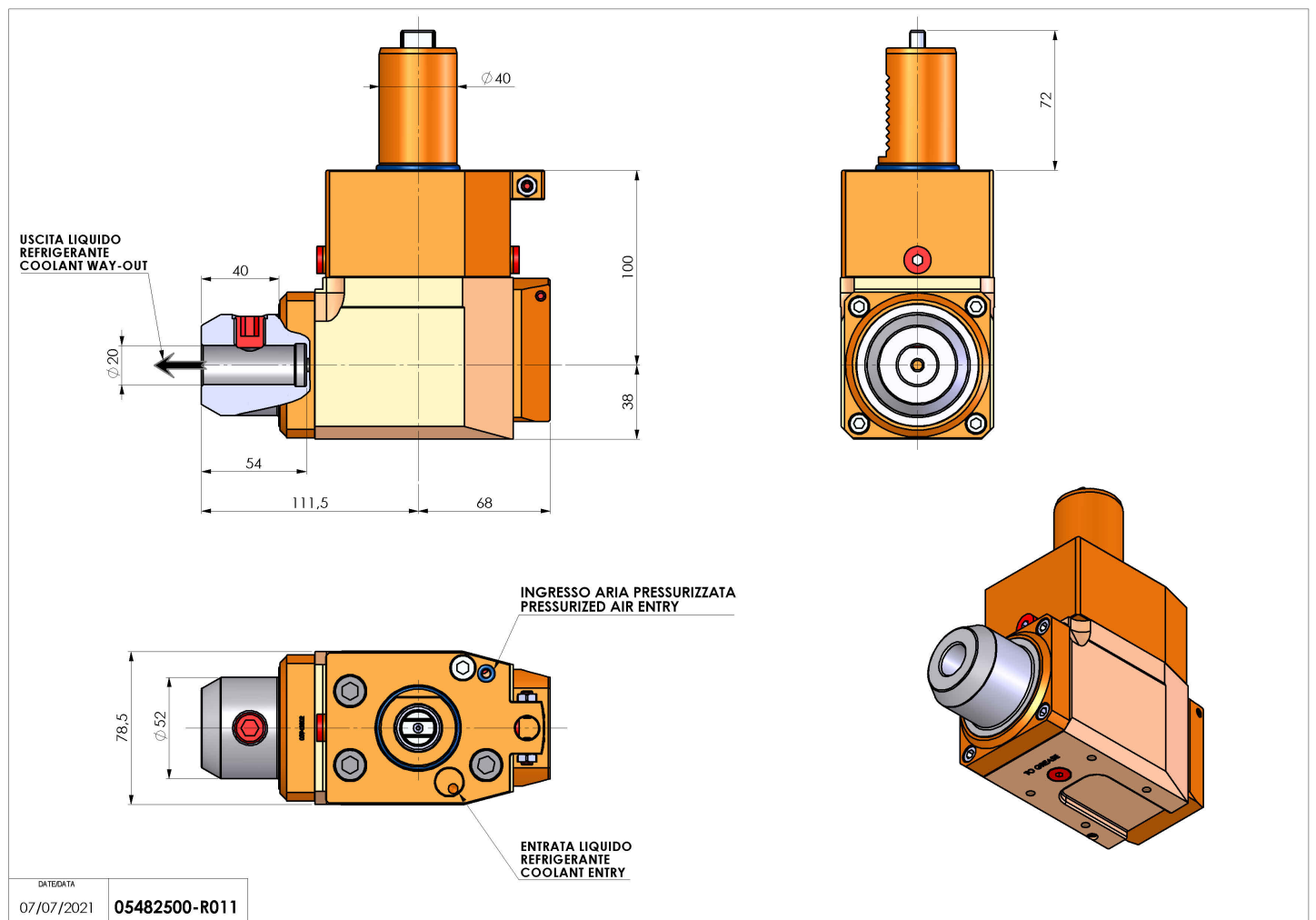

DATE/DATE
07/07/2021 05482500-R011

Subject to technical changes