

05455100 - LT-A VDI40 DIN138-27 L H100 MZ

Type	LT-A Tool holder angle 90°
Mounting	VDI 40
Tool output	Shell-Mill DIN138 27
Coolant	External coolant
Direction of rotation	r1 ↻ r2 ↻
Max speed [rpm]	6000
Max torque [Nm]	63
Ratio	1:1
H [mm]	100
H1 [mm]	39
Accessories	N.A.
Notes	N.A.
Mounting tips	Main spindle only

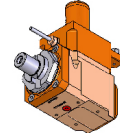

ATTENTION: CHECK THE ORIENTATION OF THE VDI TEETH

Always check live tool dimensions on the turret

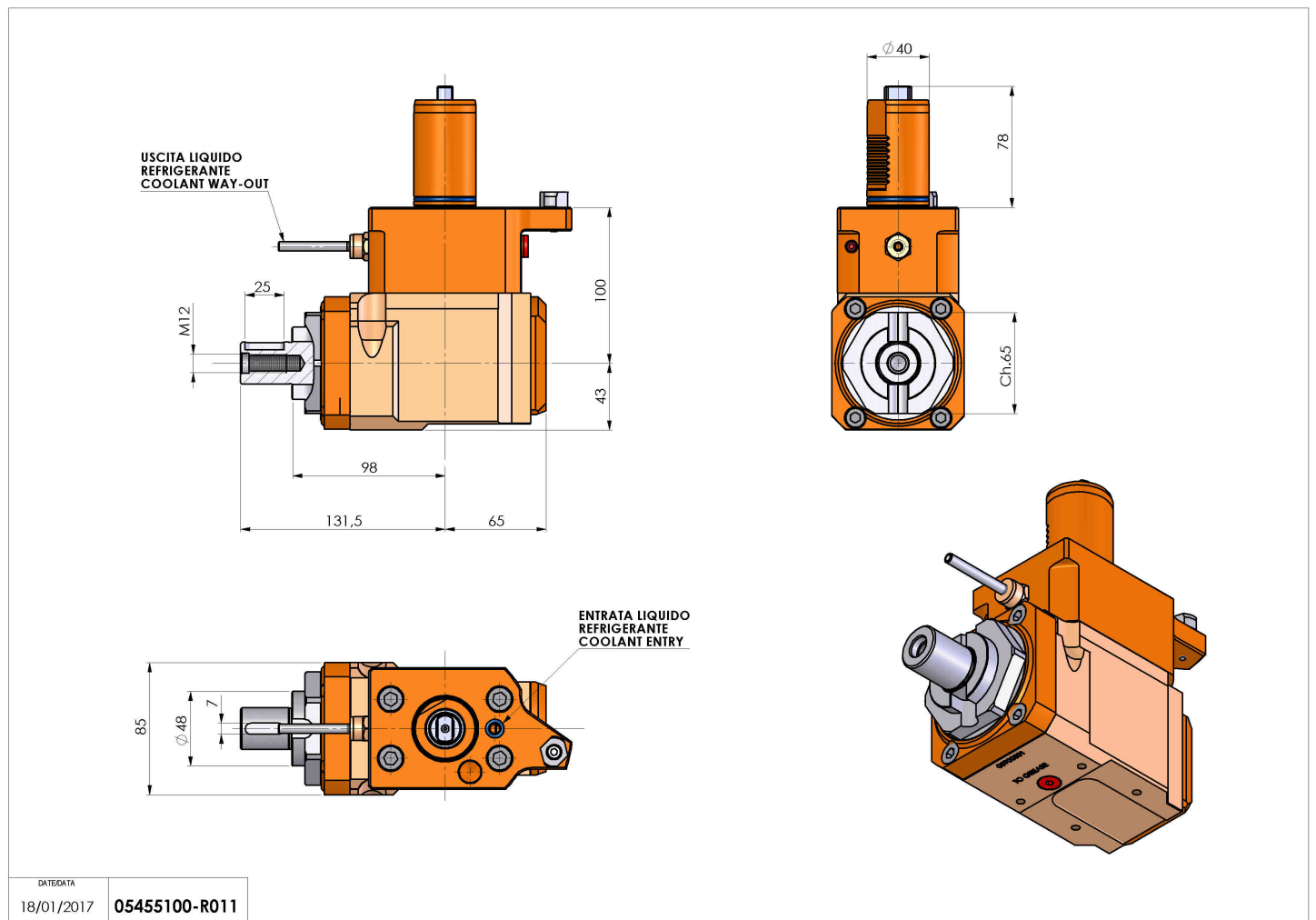

DATE/DATE	18/01/2017
	05455100-R011

Subject to technical changes