

05454000 - LT-S D80 DIN138-22 H81.5

Type	LT-S Tool holder straight
Mounting	CYLINDRICAL SHANK 80
Tool output	Shell-Mill DIN138 22
Coolant	External coolant
Direction of rotation	r1 r2
Max speed [rpm]	6000
Max torque [Nm]	80
Ratio	1:1
H [mm]	81.5
Accessories	N.A.
Notes	N.A.
Mounting tips	N.A.

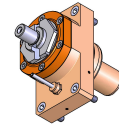

Always check live tool dimensions on the turret

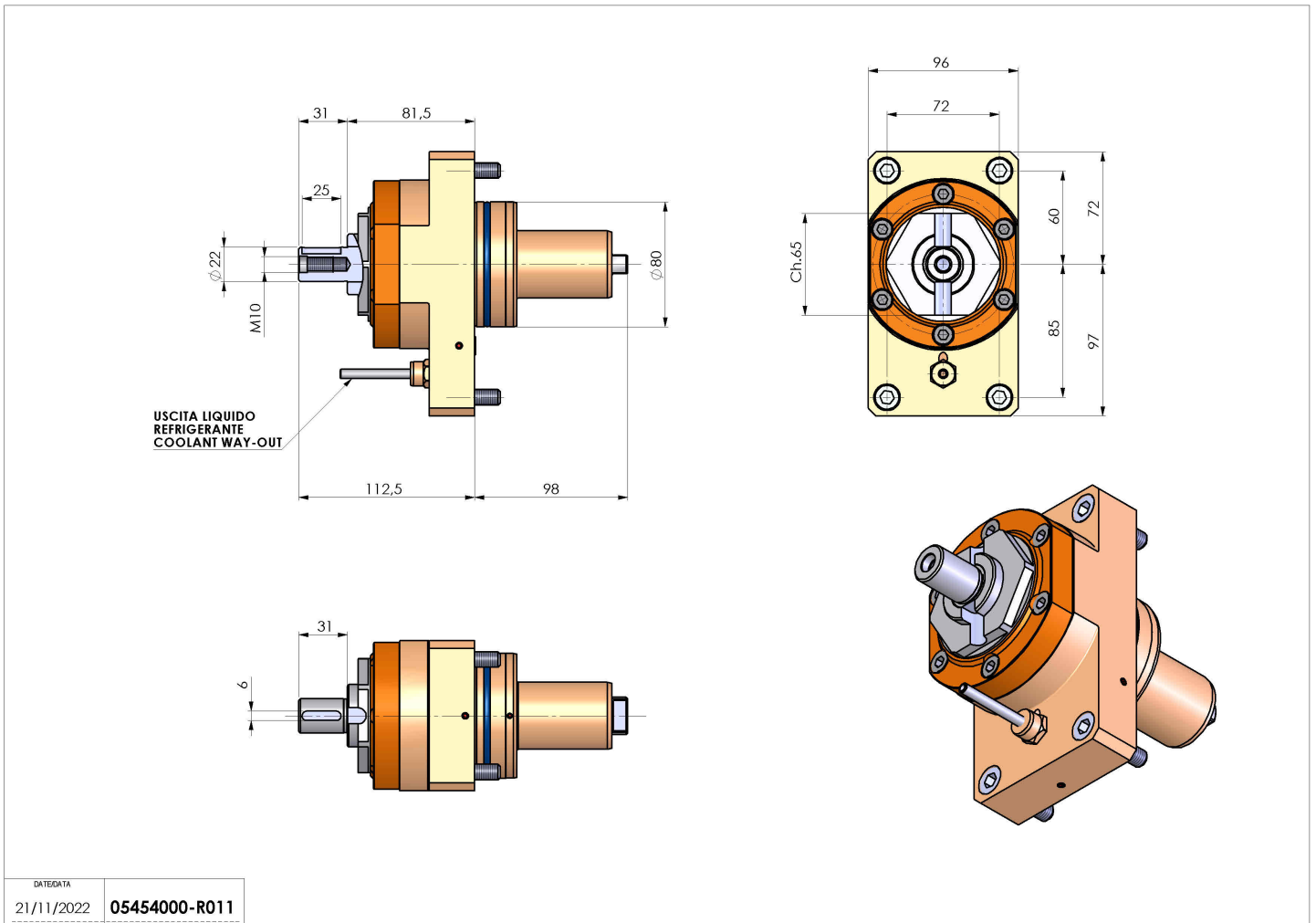

DATE/DATE	05454000-R011
21/11/2022	

Subject to technical changes