

05453200 - LT-A ST65 VDI50 C16 CR-AY H160

Type	LT-A ST Slotting tool 90°
Mounting	VDI 50
Tool output	Tool diameter 16
Coolant	External coolant
Max speed [rpm]	700
Max torque [Nm]	17.5
Ratio	1:1
Y axis adjustment	SI
Feed pushing [N]	1000
Stroke [mm]	65
Work stroke [mm]	60
Y axis adjust. [mm]	±0,4
H [mm]	160
Accessories	N.A.
Notes	N.A.
Mounting tips	N.A.

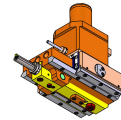

ATTENTION: CHECK THE ORIENTATION OF THE VDI TEETH

Always check live tool dimensions on the turret

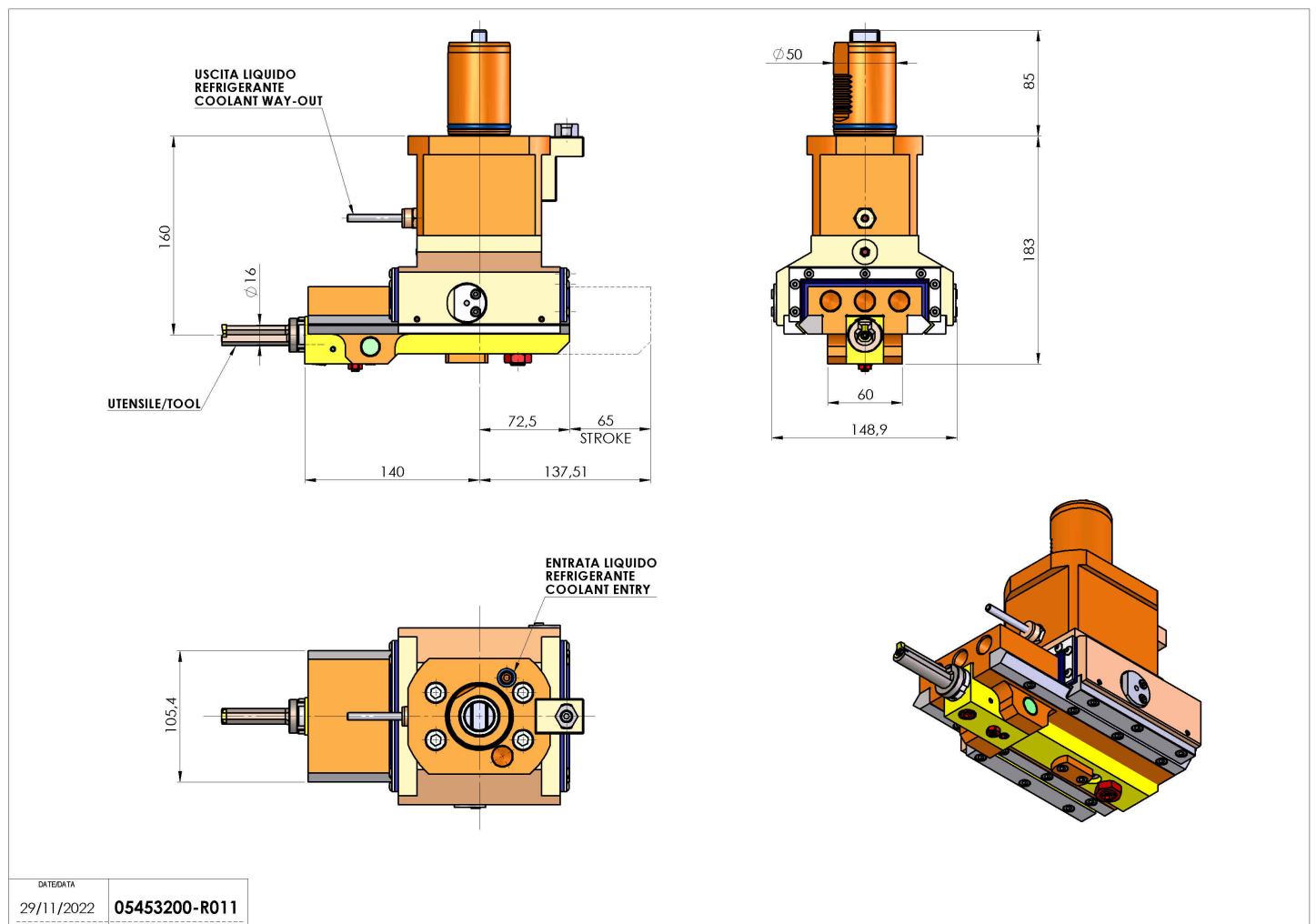

DATE/GATE	05453200-R011
29/11/2022	

Subject to technical changes