



05453000 - LT-S VDI50 C50 HRF H105

Type	LT-S Tool holder straight
Mounting	VDI 50
Tool output	Polygonal shank C50 ISO 26623-1
Coolant	HRF Internal coolant
Direction of rotation	r1  r2 
Max speed [rpm]	6000
Max torque [Nm]	140
Ratio	1:1
H [mm]	105
Max pressure [bar]	70
Accessories	N.A.
Notes	N.A.
Mounting tips	N.A.

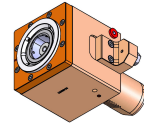

ATTENTION: CHECK THE ORIENTATION OF THE VDI TEETH

Always check live tool dimensions on the turret

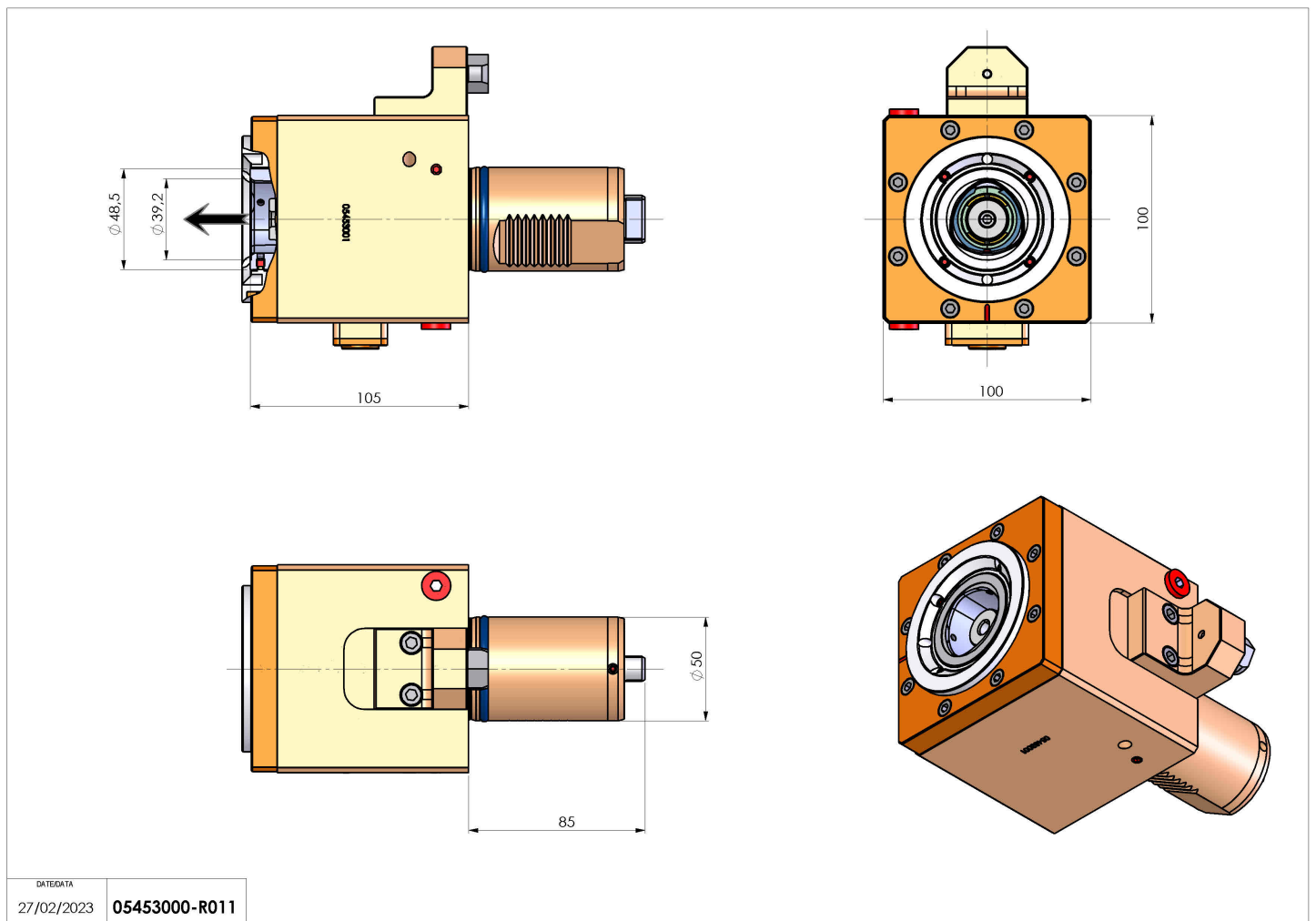

DATE/DATE	05453000-R011
27/02/2023	

Subject to technical changes