

05452900 - LT-A VDI50CAT40V40 R H160

Type	LT-A Tool holder angle 90°
Mounting	VDI 50
Tool output	Quick Change CAT40
Coolant	External coolant
Direction of rotation	r1 ↻ r2 ↻
Max speed [rpm]	6000
Max torque [Nm]	180
Ratio	1:1
H [mm]	160
H1 [mm]	52
Accessories	N.A.
Notes	N.A.
Mounting tips	Secondary spindle only

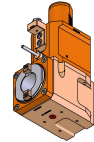

ATTENTION: CHECK THE ORIENTATION OF THE VDI TEETH

Always check live tool dimensions on the turret

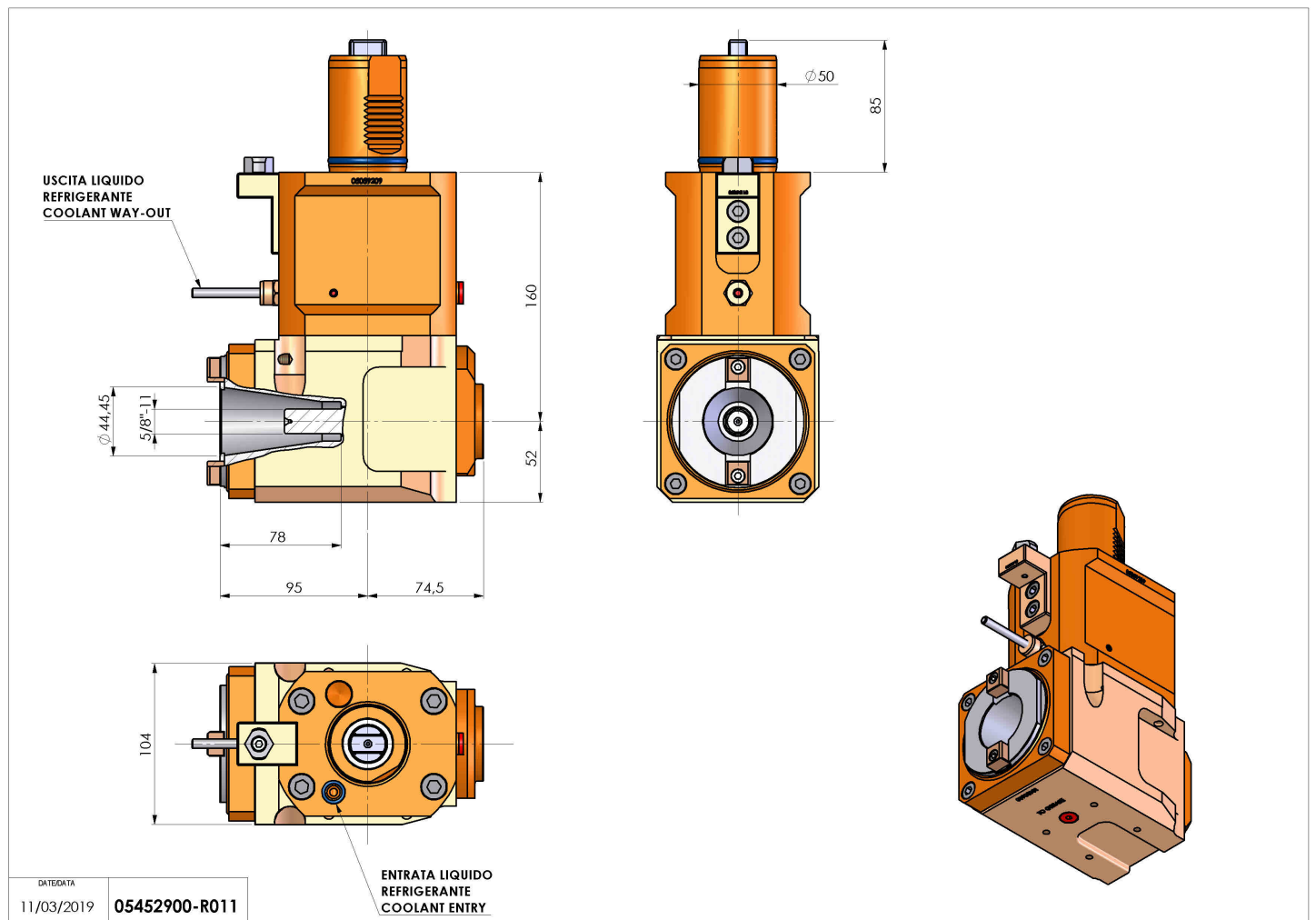

Subject to technical changes