

05450800 - LT-S D68 ER32F OFS78 HRF H95

Type	LT-S OFS Tool holder straight offset
Mounting	CYLINDRICAL SHANK 68
Tool output	Collet nut ER 32 F - internal nut
Coolant	HRF Internal coolant
Offset [mm]	78
Direction of rotation	r1 r2
Max speed [rpm]	6000
Max torque [Nm]	50
Ratio	1:1
H [mm]	95
Max pressure [bar]	80
Accessories	N.A.
Notes	N.A.
Mounting tips	Main spindle only

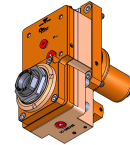

Always check live tool dimensions on the turret

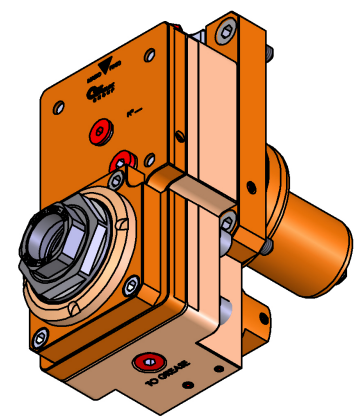
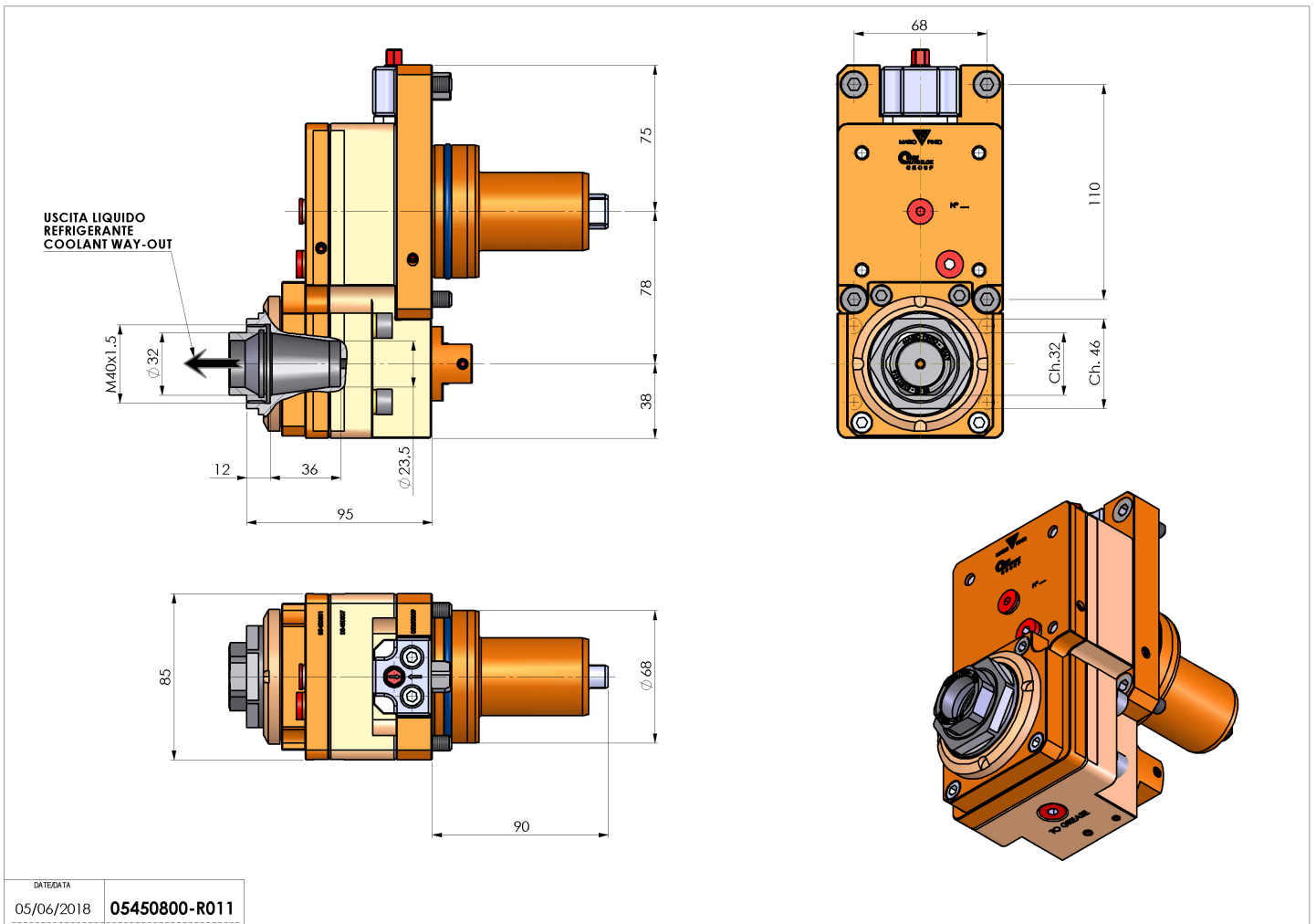

Subject to technical changes

DATE/DATE	05/06/2018
PART NUMBER	05450800-R011