

05450100 - LT-A D68 ER32F-32F HS H80

Type	LT-A DBL Tool holder double angle 90°
Mounting	CYLINDRICAL SHANK 68
Tool output	Collet nut ER 32 F - internal nut
Coolant	External coolant
Direction of rotation	r1 ↻ r2 ↻ r3 ↻
Max speed [rpm]	10000
Max torque [Nm]	63
Ratio	1:1
H [mm]	80
H1 [mm]	38
Accessories	N.A.
Notes	Replaced by cod. 05450400
Mounting tips	Main spindle only

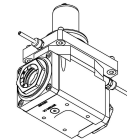

REPLACED BY 05450400

Always check live tool dimensions on the turret

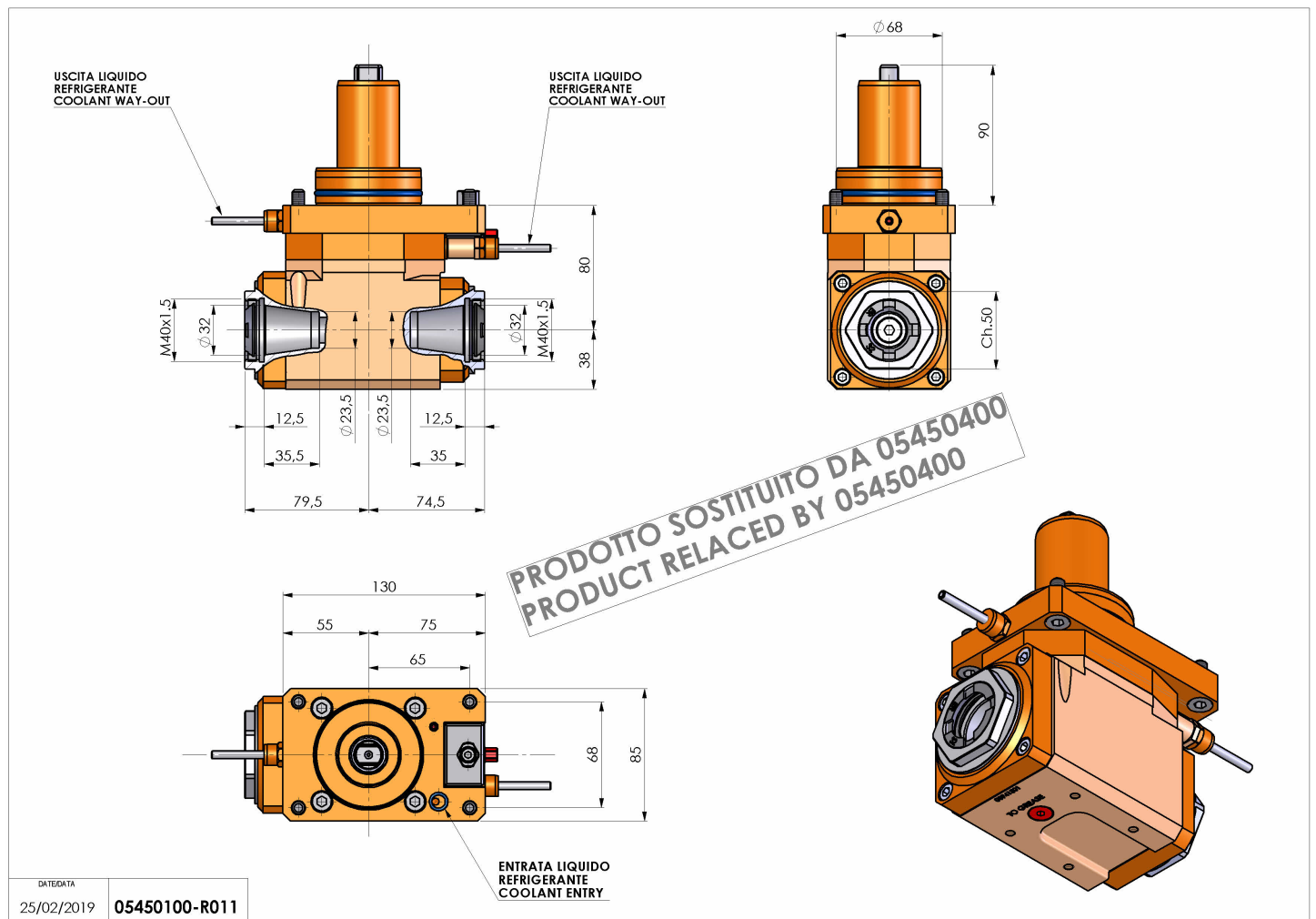

Subject to technical changes