

05411800 - LT-A D55 ER25F HRF 1:2 H75

Type	LT-A Tool holder angle 90°
Mounting	CYLINDRICAL SHANK 55
Tool output	Collet nut ER 25 F - internal nut
Coolant	HRF Internal coolant
Direction of rotation	r1 r2
Max speed [rpm]	in 6000 / out 12000
Max torque [Nm]	in 30 / out 15
Ratio	1:2
H [mm]	75
H1 [mm]	32,5
Max pressure [bar]	80
Accessories	N.A.
Notes	N.A.
Mounting tips	N.A.

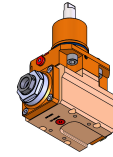

Always check live tool dimensions on the turret

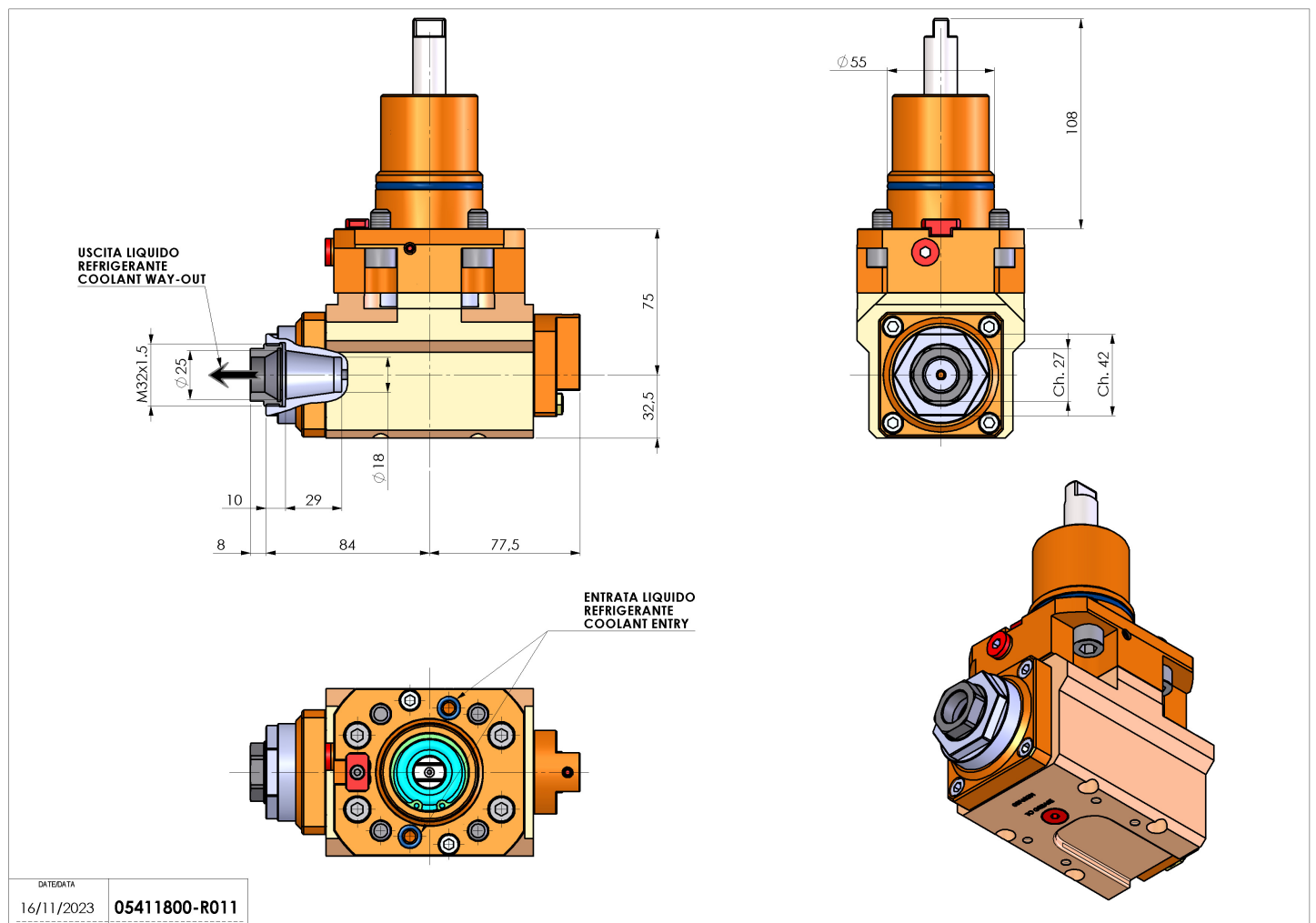

DATE/DATE	16/11/2023	05411800-R011
-----------	------------	---------------

Subject to technical changes