



05411100 - LT-S D44 ER20F OFS36.75 1:2 H68

Type	LT-S OFS Tool holder straight offset
Mounting	CYLINDRICAL SHANK 44
Tool output	Collet nut ER 20 F - internal nut
Coolant	External coolant
Offset [mm]	36,75
Direction of rotation	r1  r2 
Max speed [rpm]	in 6000 / out 12000
Max torque [Nm]	in 30 / out 15
Ratio	1:2
H [mm]	68
Accessories	N.A.
Notes	N.A.
Mounting tips	N.A.



Always check live tool dimensions on the turret

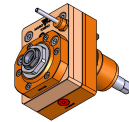
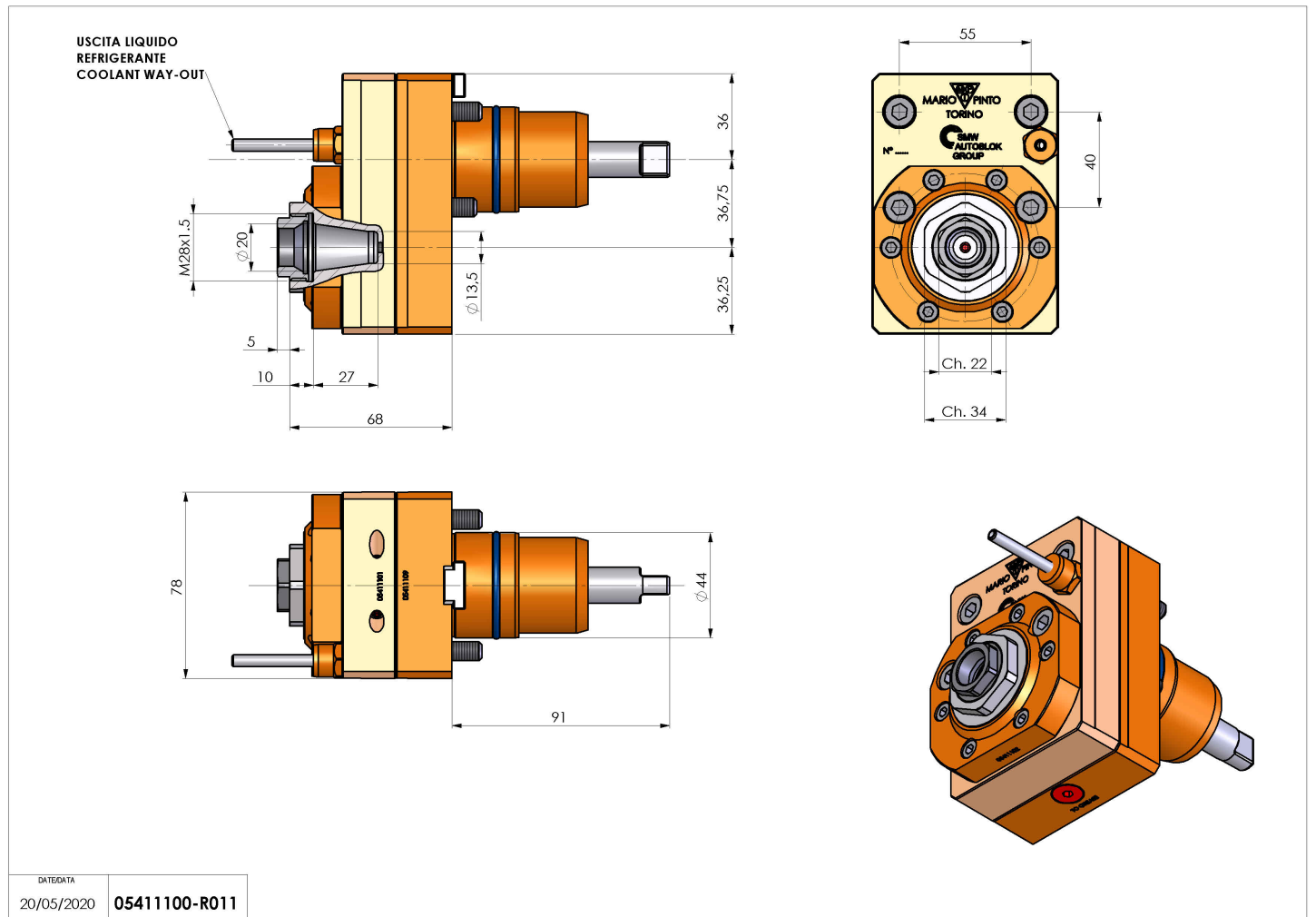

Subject to technical changes