

05402000 - LT-A D60 ER32F LR H90

| | |
|------------------------------|-----------------------------------|
| Type | LT-A Tool holder angle 90° |
| Mounting | CYLINDRICAL SHANK 60 |
| Tool output | Collet nut ER 32 F - internal nut |
| Coolant | External coolant |
| Direction of rotation | r1 ↻ r2 ↻ |
| Max speed [rpm] | 6000 |
| Max torque [Nm] | 70 |
| Ratio | 1:1 |
| H [mm] | 90 |
| Accessories | N.A. |
| Notes | N.A. |
| Mounting tips | N.A. |

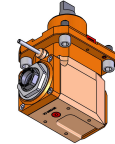

Always check live tool dimensions on the turret

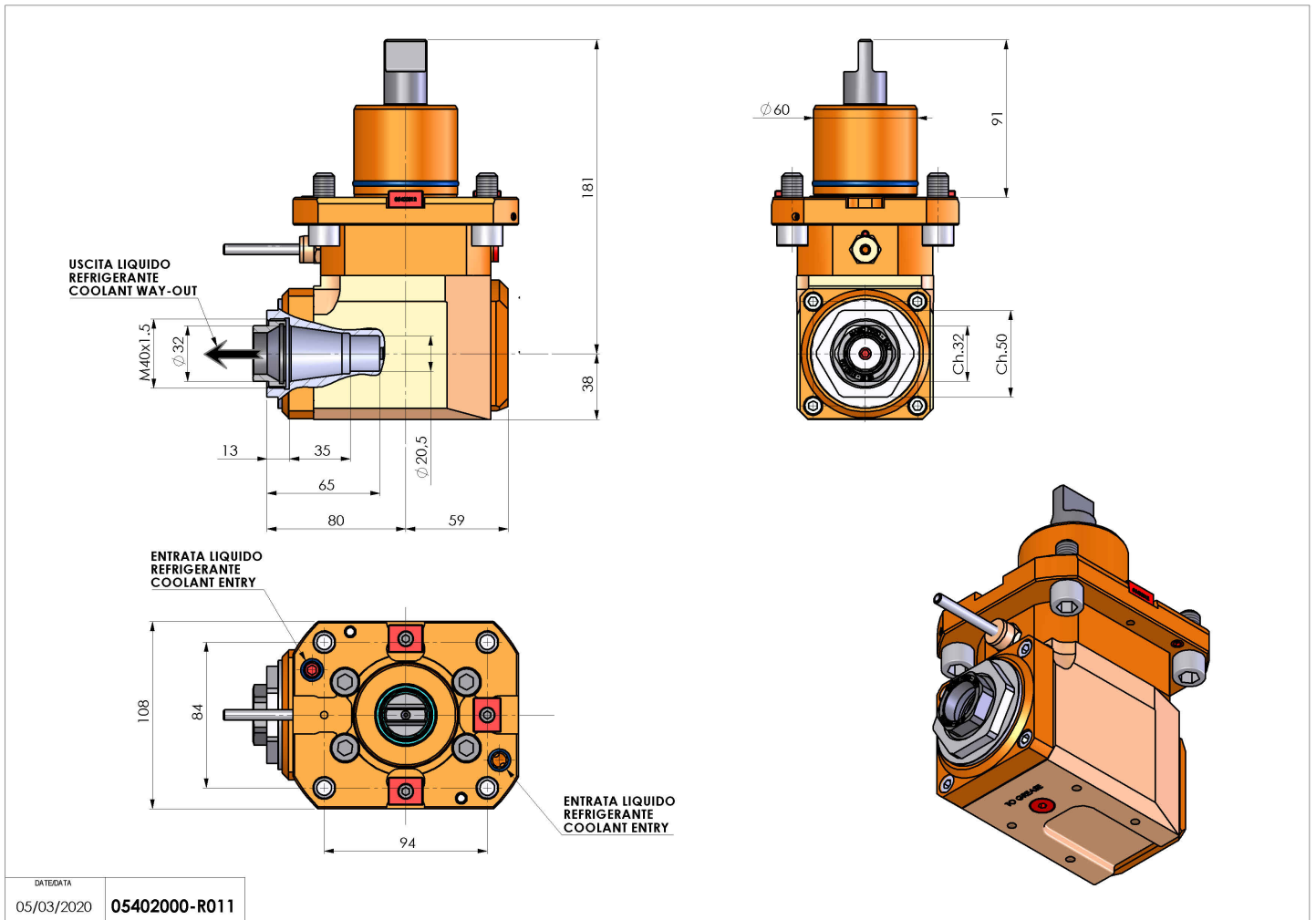

DATE/DATE: 05/03/2020 05402000-R011

Subject to technical changes