

05386400 - LT-S2 D65 I:60 ER25 OFS-75 H98

Type	LT-S2 OFS Tool holder double straight offset
Mounting	CYLINDRICAL SHANK 65
Tool output	Collet nut ER 25
Coolant	External coolant
Offset [mm]	75
Direction of rotation	
Max speed [rpm]	6000
Max torque [Nm]	70
Ratio	1:1
H [mm]	98
Accessories	N.A.
Notes	N.A.
Mounting tips	N.A.

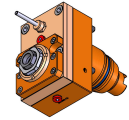

Always check live tool dimensions on the turret

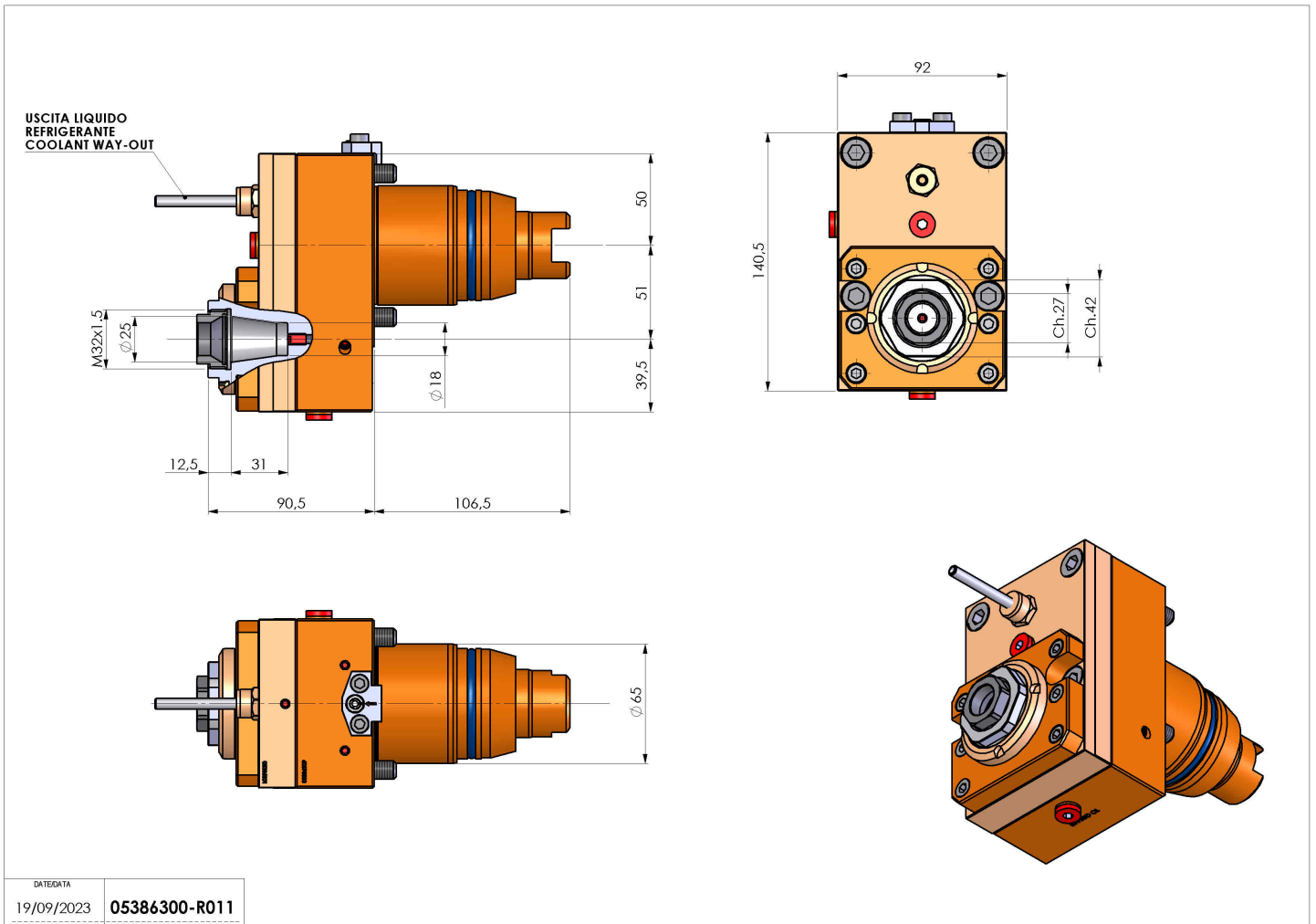

DATE/DATE	
19/09/2023	05386300-R011

Subject to technical changes