

05364100 - LT-S D55.4 ER32F OFS63.5 LR HRF 2:1 H86.5

Type	LT-S OFS Tool holder straight offset
Mounting	CYLINDRICAL SHANK 55,4
Tool output	Collet nut ER 32 F - internal nut
Coolant	HRF Internal coolant
Offset [mm]	63.5
Direction of rotation	r1 r2
Max speed [rpm]	in 6000 / out 3000
Max torque [Nm]	in 25 / out 50
Ratio	2:1
H [mm]	86.5
Max pressure [bar]	80
Accessories	N.A.
Notes	N.A.
Mounting tips	N.A.

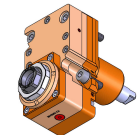

Always check live tool dimensions on the turret

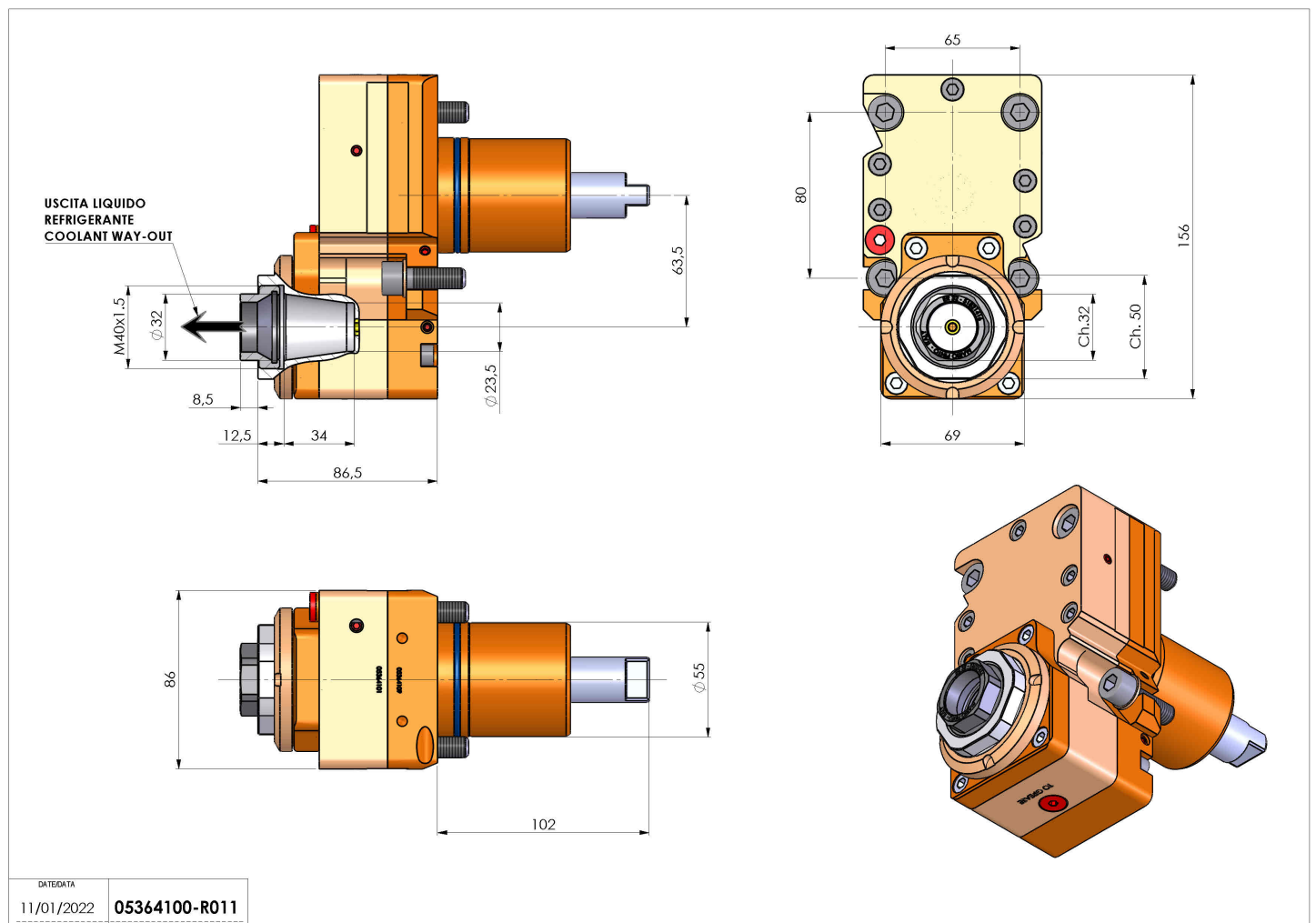

DATE/DATE	05364100-R011
11/01/2022	

Subject to technical changes