

05361000 - LT-A D60 ER32 LR HRF H110

Type	LT-A Tool holder angle 90°
Mounting	CYLINDRICAL SHANK 60
Tool output	Collet nut ER 32
Coolant	HRF Internal coolant
Direction of rotation	r1 r2
Max speed [rpm]	6000
Max torque [Nm]	63
Ratio	1:1
H [mm]	110
H1 [mm]	36
Max pressure [bar]	80
Accessories	N.A.
Notes	N.A.
Mounting tips	Right star-type turret

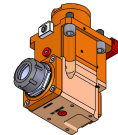

Always check live tool dimensions on the turret

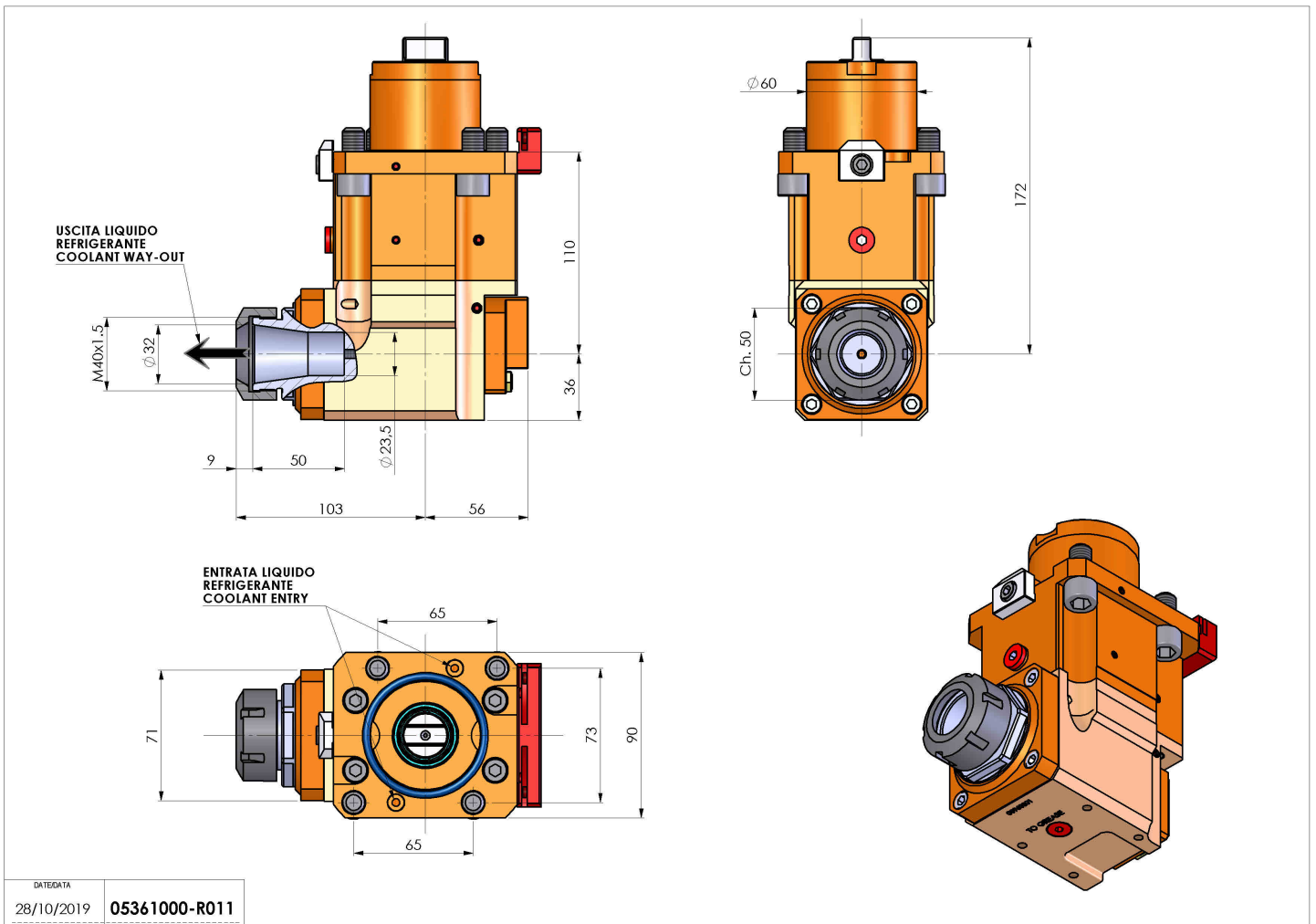

DATE/DATE	05361000-R011
28/10/2019	

Subject to technical changes